

# WIRE WIZARD<sup>®</sup>

WELDING PRODUCTS

## WIRE DELIVERY & WELDING PERIPHERAL EQUIPMENT



**FAMILY OWNED  
AMERICAN MADE**

**IF IT TOUCHES THE WIRE, THE WIZARD HAS A SOLUTION!**

[wire-wizard.com](http://wire-wizard.com)



## **EXCESS DOWNTIME**

- ▶ **All Wire Wizard® Products** are designed to help eliminate downtime!
- ▶ **Non-Stop® Wire System** — for continuous wire delivery, eliminating downtime for wire changeout
- ▶ **PowerBall® Torches & Consumables** — long consumable life reduces downtime



## **EXCESS SCRAP & POOR WELD QUALITY**

- ▶ **PowerBall® Torch Products** — consistent welding performance with unrivaled current transfer
- ▶ **PowerBall® Replacement Torch Liners** — provides smooth wire feeding for better welding consistency
- ▶ **Gas Tracker™ and Wire Tracker™** — monitors variables and detects problems to prevent bad welds



## **BURN-BACKS**

- ▶ **Torch Wizard® Nozzle Cleaning Stations** — keep nozzles free of spatter that can cause burn-backs
- ▶ **Blue Magic® Anti-spatter** — helps eliminate excess spatter buildup on the contact tip and nozzle
- ▶ **PowerBall® Torch Products** — superior cooling features prevent spatter buildup and tip deformation



## **POOR CONSUMABLE LIFE**

- ▶ **PowerBall® Torch Products** — enhanced conductivity and less heat buildup for longer consumable life
- ▶ **Torch Wizard® Nozzle Cleaning Stations** — prevents tip failure due to spatter buildup on nozzles
- ▶ **Blue Magic® Anti-spatter** — eliminates spatter buildup that can reduce nozzle and contact tip life



## **EXCESS SPATTER BUILDUP**

- ▶ **Blue Magic® Anti-spatter** — formulated for industrial use, protects against spatter buildup
- ▶ **Torch Wizard® Nozzle Cleaning Stations** — keeps torch nozzles spatter-free and prevents arc failures
- ▶ **PowerBall® Consumables** — optimized tip geometry and superior cooling prevent spatter buildup



## **WIRE TANGLING AND BIRDNESTING**

- ▶ **Wire Wizard® Guide Modules** — eliminates wire skid friction on corners for smooth wire delivery
- ▶ **PowerBall® Torch Liners** — elliptical wire liners reduce wire friction to prevent birdnesting
- ▶ **Orbital Arm Kits** — eliminates wire tangling problems inside bulk wire drums

# GET WIZARD OPTIMIZED!

## REDEFINING ARC WELDING PERFORMANCE



### WIRE WIZARD® GUIDE MODULE SYSTEM FOR MIG & SAW

Innovative design eliminates skid friction around bends and turns in the wire delivery system.



### POWERBALL® MIG WELDING GUNS & CONSUMABLES

Engineered to provide maximum conductivity and increased consumable life, proudly made in USA.



### DRUM & WOOD REEL WIRE DELIVERY EQUIPMENT

Effortlessly dispenses and protects wire from bulk wire drums or wood reels.



### POWERBALL® ROBOTIC & FIXED AUTOMATION TORCHES

Featuring patented PowerBall® technology, robotic torches available in 220° or 360° rotation.



### TORCH WIZARD® NOZZLE CLEANING STATIONS

Heavy duty, low maintenance cleaning stations designed for optimum performance and cycle time.



### POWERBALL® LONG-LASTING ELLIPTICAL WIRE TORCH LINERS

Patented elliptical wire liner for long life and low wire friction, available for most MIG gun models.



### POWERBALL® ENERGY EFFICIENT WELDING CABLE

Patent pending consolidated copper lug design for high performance and long service life.



### BLUE MAGIC® & BLUE CHILL® ANTI-SPATTER

Trusted by top manufacturers around the globe for industrial strength spatter protection.



### CONDUIT & CONNECTORS FOR MIG & SAW WIRE

Low-friction polymer and steel lined conduit built tough for industrial applications.



### WIRE PILOT® PNEUMATIC FEED ASSIST

Provides simple and effective "push-pull" system to eliminate wire skid friction in MIG and SAW welding.

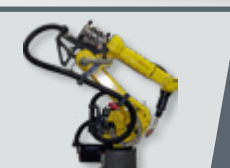

### WIZARDGEAR® ROBOT CABLE MANAGEMENT

Secures and protects cables attached to robots in harsh industrial environments.



### SUBMERGED ARC WELDING PRODUCTS

PowerBall® SAW Torch, Mechanical Turn Table and Wire Delivery Systems for Large Wire.



### DRUM & REEL HANDLING EQUIPMENT

Heavy duty, USA made drum lifters, drum and wood reel dollies, carts and more.



### GAS FLOW OPTIMIZATION PRODUCTS

Gas Wizard® Inert Gas Savers and gas flow monitoring and optimization equipment.



### TOOLS & MAINTENANCE EQUIPMENT

Wire Wizard® Wire and Welding Pliers and diagnostic tools for MIG wire delivery systems.



### NU-ICE DRY ICE CLEANING EQUIPMENT

COMMANDO® dry ice blasting machines, ideal for weld cell and production line cleaning.

# TABLE OF CONTENTS

<b>FIBER DRUM DISPENSING EQUIPMENT</b> . . . . . 2	<b>WIRE STRAIGHTENERS</b> . . . . . 24	<b>WIRE TRACKER™ DIGITAL WIRE MONITOR</b> . . . . . 40
<b>DRUM &amp; REEL HANDLING EQUIPMENT</b> . . . . . 6	<b>WIRE PILOT® FEED ASSISTS</b> . . . . . 25	<b>GAS FLOW MONITORING &amp; OPTIMIZATION</b> . . . . . 41
<b>WOOD REEL WIRE DISPENSING</b> . . . . . 8	<b>QUICK DISCONNECTS &amp; INLET GUIDES</b> . . . . . 28	<b>TOOLS &amp; MAINTENANCE EQUIPMENT</b> . . . . . 43
<b>CONDUIT &amp; CONNECTORS</b> . . . . . 9	<b>WIZARDGEAR® CABLE MANAGEMENT</b> . . . . . 32	<b>POWERBALL® TORCH PRODUCTS</b> . . . . . 44
<b>NON-STOP® WIRE DISPENSING SYSTEM</b> . . . . . 16	<b>TORCH WIZARD® NOZZLE CLEANING STATIONS</b> . . . . . 34	<b>SHIPPING &amp; TERMS</b> . . . . . 45
<b>WIRE WIZARD® GUIDE MODULE® SYSTEM</b> . . . . . 18	<b>ANTI-SPATTER &amp; ACCESSORIES</b> . . . . . 38	

## WIRE DELIVERY KIT CONFIGURATION EXAMPLES

### SAMPLE WIRE DELIVERY KIT CONFIGURATIONS

Don't know where to start with your wire delivery system? These two wire delivery system examples are designed to help configure an optimized wire delivery equipment setup for typical layouts seen in semi-automatic and robotic arc welding.

### SEMI-AUTOMATIC MIG WIRE DELIVERY SETUP EXAMPLE

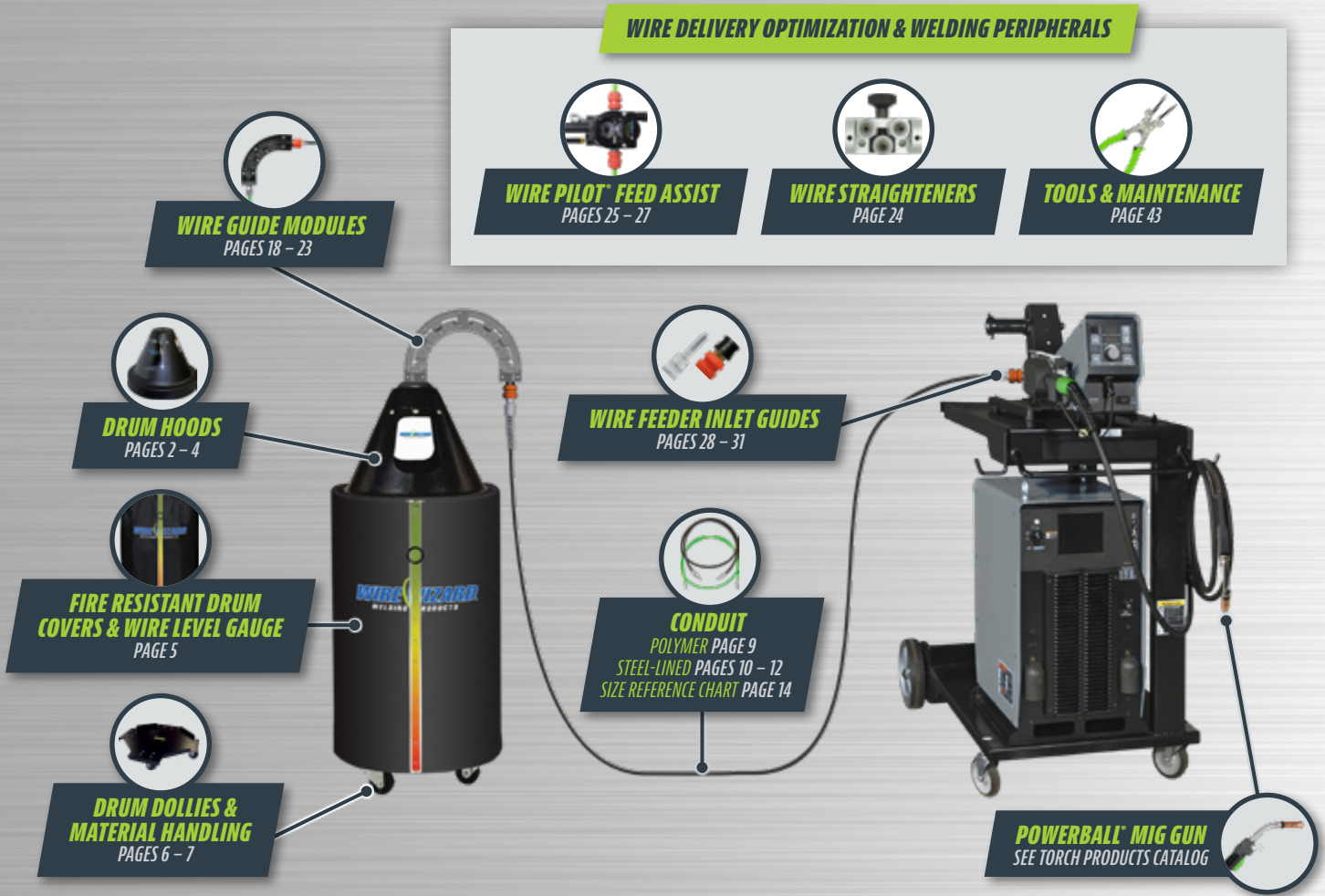

# ROBOTIC MIG WIRE DELIVERY SETUP EXAMPLE

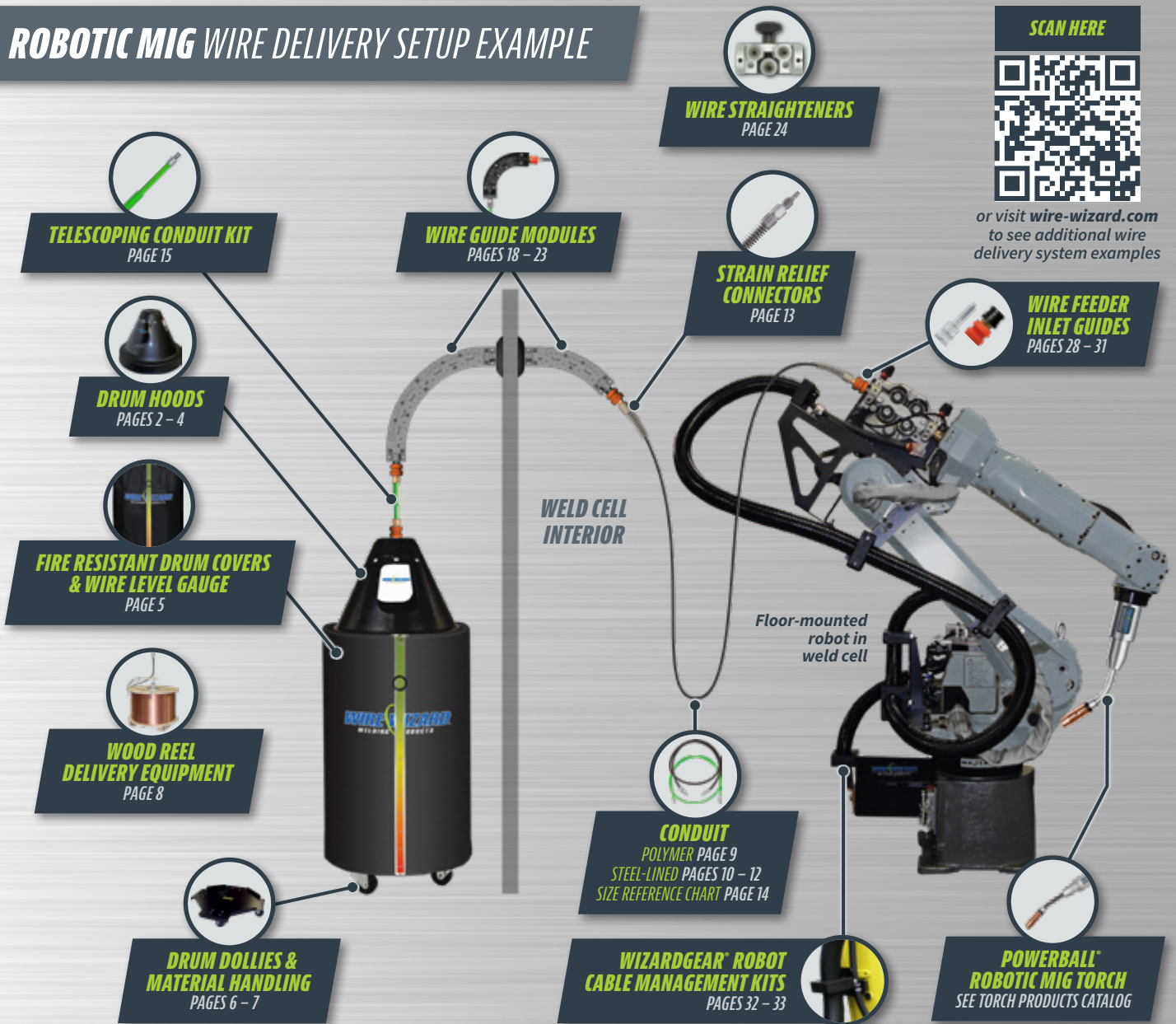

## WIRE DELIVERY OPTIMIZATION & WELDING PERIPHERALS



**NON-STOP® WIRE DELIVERY SYSTEM**  
PAGES 16 - 17



**WIRE PILOT® FEED ASSIST**  
PAGES 25 - 27

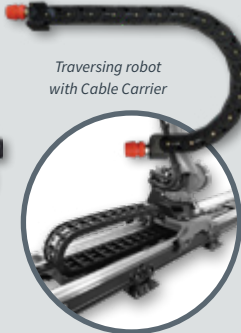

**WIRE GUIDE MODULE® FLEX**  
PAGES 22 - 23



**TORCH WIZARD® NOZZLE CLEANING STATIONS & ANTI-SPATTER**  
PAGES 34 - 39



**WELDING OPTIMIZATION TECHNOLOGY**  
PAGES 40 - 43

# FIBER DRUM DISPENSING EQUIPMENT

## DRUM HOODS

- ▶ Hood covers available for round, square and octagon shaped bulk wire packaging
- ▶ Constructed of tough polyethylene for long shop life
- ▶ Dual windows provide easy access and viewing
- ▶ Flange on hood securely anchors hood to package
- ▶ Orbital Arm or Direct Pull Kit guarantee smooth wire feeding
- ▶ **Lifetime guarantee against breakage**

Flanged hoods fit both chimed drums and environmental packs



## DIRECT PULL KIT WWDP

- ▶ Quick disconnect with polished ceramic inlet prevents wire shaving
- ▶ Fits all cone and wire sizes
- ▶ **Lifetime guarantee not to wear out**

See page 28 for fixed mount direct pull kit

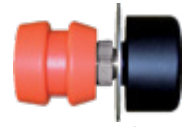

WWDP side



Ceramic inlet

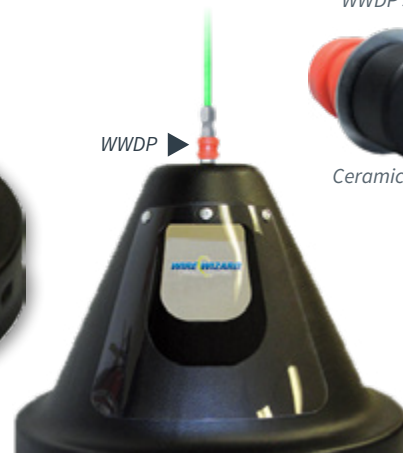

WWDP



Round Drum Hood



Square Drum Hood



Octagon Drum Hood

## WIRE PRESENCE SENSOR BLOCK & PROXIMITY SWITCH

WWSB-M12-K and WWSB-M12-K2

- ▶ Detects and signals when wire drum is empty
- ▶ Proximity switch may be connected to PLC to stop welding cycle when wire is depleted
- ▶ Uses 12 mm proximity switch, other switches available upon request
- ▶ Compatible with all Wire Wizard® drum hoods

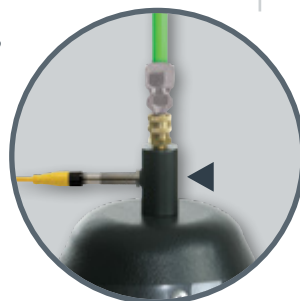

Quick disconnect not included. Requires A-4 style disconnect (1/4" NPT).

## ORBITAL ARM KITS

- ▶ Helps prevent wire from tangling inside the drum
- ▶ Arms available for all wire sizes and types up to 1/16" (1.6 mm)
- ▶ Polished ceramic inlet guide will not shave wire
- ▶ Compatible with all Wire Wizard® Drum Hoods

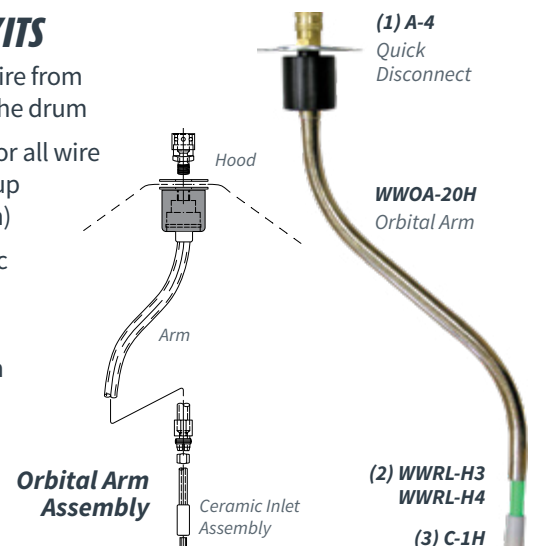

## ROUND DRUM HOODS 20" – 23" (508 – 584 mm) hoods fit both chimed drums and environmental packs

	Part No.	Description
	WW10204F	20.4" (518 mm) Round Hood
	WW10204F-DP	20.4" (518 mm) Round Hood with Direct Pull Kit
	WW10231F	23" (584 mm) Round Hood
	WW10231F-DP	23" (584 mm) Round Hood with Direct Pull Kit
	WW10260F	26" (660 mm) Round Hood
	WW10260F-DP	26" (660 mm) Round Hood with Direct Pull Kit

## SQUARE DRUM HOODS

	Part No.	Description
	WWSC-21	21" (533 mm) Square Hood (500 lb / 227 kg)
	WWSC-21DP	21" (533 mm) Square Hood with Direct Pull Kit (500 lb / 227 kg)
	WWSC-24	24" (610 mm) Square Hood (1,000 lb / 453 kg)
	WWSC-24DP	24" (610 mm) Square Hood with Direct Pull Kit (1,000 lb / 453 kg)
	WWSC-29	29" (737 mm) Square Hood (990 lb / 449 kg) — <i>Special order item; contact Customer Support</i>

## OCTAGON DRUM HOODS

	Part No.	Description
	WWOC-20.5	20.5" (521 mm) Octagon Hood (500 lb / 227 kg)
	WWOC-20.5-DP	20.5" (521 mm) Octagon Hood with Direct Pull Kit (500 lb / 227 kg)
	WWOC-21.5	21.5" (546 mm) Octagon Hood (500 lb / 227 kg)
	WWOC-21.5-DP	21.5" (546 mm) Octagon Hood with Direct Pull Kit (500 lb / 227 kg)
	WWOC-23.5	23.5" (597 mm) Octagon Hood (900 lb / 408 kg)
	WWOC-23.5-DP	23.5" (597 mm) Octagon Hood with Direct Pull Kit (900 lb / 408 kg)
	WWOC-24.5	24.5" (622 mm) Octagon Hood (1,000 lb / 453 kg)
	WWOC24.5-DP	24.5" (622 mm) Octagon Hood with Direct Pull Kit (1,000 lb / 453 kg)

## ORBITAL ARM KITS with Quick Disconnect

	Part No.	Description
	WWOA-20	Compatible with 20" (508 mm) – 23.4" (594 mm) hood for up to 0.062 (1.6 mm); Steel or Cored Wire
	WWOA-20H	Compatible with 20" (508 mm) – 23.4" (594 mm) hood for up to 0.062 (1.6 mm); Steel or Aluminum/Non-ferrous Wire

## ORBITAL ARM REPLACEMENT PARTS

Part No.	Description
A-4	(1) Quick Disconnect (QD)
WWRL-H3	(2) Replacement Liner for WWOA-20
WWRL-H4	(2) Replacement Liner with Inlet Guide for WWOA-20H
C-1H	(3) Inlet Guide with Ceramic Insert

## ADDITIONAL EQUIPMENT

Part No.	Description
WWDP	Direct Pull Kit
WWSB-M12-K	Sensor Block and Proximity Switch Kit (PNP) ( <i>quick disconnect not included; requires A-4 style disconnect – 1/4" NPT</i> )
WWSB-M12-K2	Sensor Block and Proximity Switch Kit (NPN) ( <i>quick disconnect not included; requires A-4 style disconnect – 1/4" NPT</i> )
WWSB-M12	Sensor Block (12 mm)
WWA5-E34	Proximity Switch (PNP)
WWA5-E35	Proximity Switch (NPN)
WWDI	Conduit Connection Insulator

## DRUM MANUFACTURER CROSS-REFERENCE CHART FOR HOODS\*

Wire Manufacturer	Packaging	Drum Diameter
Air Liquide®	500 lb (227 kg)	20.4" (518 mm)
	900 lb (408 kg)	23.4" (594 mm)
Arcos Alloys®	250 lb (113 kg)	20.4" (518 mm)
	500 lb (227 kg)	20.4" (518 mm)
Avesta®	250 lb (113 kg)	20.4" (518 mm)
	550 lb (250 kg)	20.4" (518 mm)
	600 lb (272 kg)	20.4" (518 mm)
	750 lb (340 kg)	26.0" (660 mm)
Böhler®	550 lb (250 kg)	20.4" (518 mm)
Eagle®	500 lb (227 kg)	20.4" (518 mm)
ESAB®	500 lb (227 kg)	20.4" (518 mm)
	550 lb (250 kg)	20.4" (518 mm)
	900 lb (408 kg)	23.4" (594 mm)
	500 lb (227 kg) – Octagon	20.5" (521 mm)
	600 lb (272 kg) – Octagon	20.5" (521 mm)
Gedik® (GeKa®)	110 lb (50 kg)	20.4" (518 mm)
	485 lb (220 kg)	20.4" (518 mm)
Grytgols Bruk®	550 lb (250 kg)	23.4" (594 mm)
	500 lb (227 kg)	20.4" (518 mm)
Harris Welco®	1,000 lb (453 kg)	26.0" (660 mm)
	500 lb (227 kg)	20.4" (518 mm)
Hyundai®	< 600 lb (272 kg)	20.4" (518 mm)
	> 600 lb (272 kg)	26.0" (660 mm)
Hobart®	250 lb (113 kg)	23.4" (594 mm)
	400 lb (181 kg)	20.4" (518 mm)
	500 lb (227 kg) – Tubular	20.4" (518 mm)
	600 lb (272 kg) – Solid	20.4" (518 mm)
	600 lb (272 kg) – Tubular	23.4" (594 mm)
	700 lb (318 kg) – Tubular	23.4" (594 mm)
INE®	950 lb (431 kg) – Solid	23.4" (594 mm)
	440 lb (200 kg)	20.4" (518 mm)
	550 lb (250 kg)	20.4" (518 mm)
Pittarc®	1,325 lb (600 kg)	26.0" (660 mm)
	661 lb (300 kg)	20.4" (518 mm)
Kaynak®	550 lb (250 kg)	20.4" (518 mm)
Kobelco®	550 lb (250 kg)	20.4" (518 mm)
	660 lb (299 kg)	20.4" (518 mm)

Wire Manufacturer	Packaging	Drum Diameter
Lincoln Electric®	500 lb (227 kg)	20.4" (518 mm)
	600 lb (272 kg)	23.4" (594 mm)
	900 lb (408 kg)	23.4" (594 mm)
	1,000 lb (453 kg)	23.4" (594 mm)
	1,000 lb (453 kg) – Large Round	26.0" (660 mm)
	275 lb (125 kg) – Square	24.0" (610 mm)
	500 lb (227 kg) – Square	21.0" (553 mm)
	900 lb (408 kg) – Square	24.0" (610 mm)
	1,000 lb (453 kg) – Square	24.0" (610 mm)
	2,000 lb (907 kg) – Large Square	29.0" (737 mm)
National Standard®	500 lb (227 kg) – Octagon	21.5" (546 mm)
	1,000 lb (453 kg) – Octagon	24.5" (622 mm)
	400 lb (181 kg)	20.4" (518 mm)
	500 lb (227 kg)	20.4" (518 mm)
	900 lb (408 kg)	23.4" (594 mm)
Nexalloy®	150 lb (68 kg)	23.5"
	300 lb (136 kg)	23.5"
Novafil®	330 lb (150 kg)	23.5"
	550 lb (250 kg)	20.4" (518 mm)
Paramount®	500 lb (227 kg)	20.4" (518 mm)
	1,000 lb (453 kg)	26.0" (660 mm)
Pittarc® (Pittini)	550 lb (250 kg)	20.4" (518 mm)
	772 – 992 lb (350 – 450 kg)	23.4" (594 mm)
PolyMet®	1,323 – 1,543 lb (600 – 700 kg)	26.0" (660 mm)
	Round drums	23.4" (594 mm)
Praxair® (ProStar®)	275 lb (125 kg) – Square	21.0" (533 mm)
	550 lb (250 kg) – Square	21.0" (533 mm)
Sandvik®	600 lb (272 kg)	20.4" (518 mm)
	250 lb (113 kg)	20.4" (518 mm)
Select-Arc® <i>for 5/64"/2 mm or larger diameter wire use 23.4" (594 mm) drum hoods</i>	400 lb (181 kg)	20.4" (518 mm)
	500 lb (227 kg)	20.4" (518 mm)
	600 lb (272 kg)	23.4" (594 mm)
	110 – 200 (50-91 kg)	23.4" (594 mm)
Stoody®	500 lb (227 kg)	23.4" (594 mm)
	750 lb (340 kg)	23.4" (594 mm)
	No Twist Pak (NTP) – Various sizes	20.4" (518 mm)
Tri-Mark®	400 lb (181 kg)	20.4" (518 mm)
	500 lb (227 kg)	20.4" (518 mm)
Washington Alloys®	600 lb (272 kg)	23.4" (594 mm)
	500 lb (227 kg)	20.4" (518 mm)
Weldmark®	500 lb (227 kg)	20.4" (518 mm)
	1,000 lb (453 kg)	26.0" (660 mm)
Wisconsin Wire Works®	250 lb (113 kg)	20.4" (518 mm)
	500 lb (227 kg)	20.4" (518 mm)

\* Drum sizes have been supplied by the manufacturer or their distributors who, at their discretion, reserve the right to change product standards without notice. To the best of ELCo's knowledge, information presented is accurate and current.  
**All packaging is round unless otherwise noted.**

## DRUM DOLLIES 1,000 lb/453 kg capacity. See all dollies and carts on pages 6 – 7. For drums/boxes up to 25" (635 mm) - use FDD-MD-LD for 29" packages



**Universal Drum Dolly**  
**FDD-MD**

For drums/boxes  
 25" (635 mm) and under

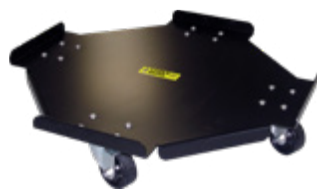

**Large Universal Drum Dolly**  
**FDD-MD-LD**

For drums/boxes between  
 25 – 30" (635 – 762 mm)



**FDSC-13**  
 Heavy Duty Drum Staging Cart



**WWS D**  
 Skid Dolly  
 (27.5" (698.5 mm) square)

## FIRE RESISTANT FIBER DRUM & BOX COVERS

For 20.4" to 26" round, square or octagon bulk packages

Wire Wizard® durable fire resistant covers provide effective protection for fiber or cardboard packaging located near the weld cell. Available for round, square or octagon bulk wire packages.

- ▶ Constructed of tough fire resistant material
- ▶ Simple slip-on/slip-off design
- ▶ OSHA and NFPA (USA) codes require fire protection for any combustible wire packaging within 35 feet (10.7 m) of the arc
- ▶ Covers meet NFPA Code 51b: "Standard for Fire Prevention During Welding, Cutting and Other Hot Work"

Part No.	Description
WWDC-20.4-R	Fire Resistant Drum Cover — Round 20.4" (518.2 mm)
WWDC-23.4-R	Fire Resistant Drum Cover — Round 23.4" (594.4 mm)
WWDC-26-R	Fire Resistant Drum Cover — Round 26" (660 mm)
WWDC-21-S	Fire Resistant Drum Cover — Square 21" (533.4 mm)
WWDC-24-S	Fire Resistant Drum Cover — Square 24" (609.6 mm)
WWDC-20.5-OC	Fire Resistant Drum Cover — Octagon 20.5" (520.1 mm)
WWDC-23.5-OC	Fire Resistant Drum Cover — Octagon 23.5" (597 mm)



### FROM OSHA.GOV WEBSITE

[https://www.osha.gov/pls/oshaweb/owadisp.show\\_document?p\\_table=STANDARDS&p\\_id=9853](https://www.osha.gov/pls/oshaweb/owadisp.show_document?p_table=STANDARDS&p_id=9853)

#### Standard Number: 1910.252(a)(2)(vii)

Relocation of combustibles. Where practicable, all combustibles shall be relocated at least 35 feet (10.7 m) from the work site. Where relocation is impracticable, **combustibles shall be protected with flameproofed covers** or otherwise shielded with metal or asbestos guards or curtains.

For details on NFPA Standards, see NFPA Code 51b documentation, available through [www.nfpa.org](http://www.nfpa.org).

## WIRE LEVEL GAUGE FOR DRUMS & BOXES

- ▶ Features magnetic wire detection that slides down the drum as wire is depleted, offering a convenient way to monitor wire usage.
- ▶ Detects wire level in the drum with colors and percentages
- ▶ Compatible with 500 – 1,000 lb (227 – 453 kg) drums/boxes (reversible design)
- ▶ Compatible with solid steel wires in fiber drum or boxed packaging (incompatible cored/non-ferrous wire)

Part No.	Description
DLG	Wire Level Gauge for 500 – 1,000 lb (227 – 453 kg) drums/boxes



## DIGITAL DRUM LEVEL SENSOR

- ▶ Utilizes an inductive sensor with PNP output to detect and signal when wire is below a set location on the wire package
- ▶ Requires connection to a PLC or robot controller (M12 x 1, 4-pin connection). Cable not included.
- ▶ Compatible with 500 – 1,000 lb (227 – 453 kg) drums/boxes (adjustable design)
- ▶ Compatible with most ferrous and non-ferrous wires (wire must be less than 2" from sensor for proper functionality)

Part No.	Description
DLS	Drum Level Sensor for 500 – 1,000 lb (227 – 453 kg) drums/boxes



# DRUM & REEL HANDLING EQUIPMENT

## UNIVERSAL DRUM DOLLIES *FDD-MD or FDD-MD-LD*

- ▶ Reversible design for large and small wire packages
- ▶ Textite wheels and roller bearings for ease of rollability
- ▶ Also compatible with 55 gallon drums of anti-spatter
- ▶ Use FDD-MD-LD or WWSD for packages over 25" (635 mm)
- ▶ Standard UPS shipping available

### SPECIFICATIONS

- ▶ Deck Height: 4.25" (108 mm)
- ▶ Weight: 26 lbs (11.8 kg)
- ▶ Capacity: 1,000 lbs (453 kg)\*

## Universal Drum Dolly *FDD-MD*

Swivel casters on 2 wheels

## *FDD-MD-SW*

Swivel casters on all wheels

For drums/boxes 25" (635 mm) and under



## Large Universal Drum Dolly *FDD-MD-LD*

For drums/boxes between 25 – 30" (635 – 762 mm)



## SKID DOLLY *WWSD*

Capable of handling up to 1,000 pounds\*, this dolly can be used with all drums/boxes on skids or pallets measuring 27 inches square or smaller. Four solid Textite roller bearing wheels make transporting a drum simple. Can be assembled in a lip up or lip down configuration depending on customer needs.

### SPECIFICATIONS

- ▶ Deck Height: 4.5" (114.3 mm)
- ▶ Dimensions: 5" (127 mm) H x 27.5" (698.5 mm) L x 27.5" (698.5 mm) W
- ▶ Capacity: 1,000 lbs (453 kg)\*
- ▶ Weight: 38 lbs (17.24 kg)



## HEAVY DUTY DRUM STAGING CART *FDSC-13*

Designed for one person to transport up to 1,000 pound (453 kg)\* wire drums. The hinged handle stores upright for pushing and outward to give added leverage for easy steering. Non-conductive Textite 6" (152.4 mm) roller bearing wheels and 3" (76.2 mm) front swivel caster provide smooth movement and maximum maneuverability over all surfaces.

- ▶ Transports drums up to 24" (610 mm) in diameter
- ▶ Optional positive locking brake system (add "B" to part number)
- ▶ Suitable for UPS shipping

### SPECIFICATIONS

- ▶ Deck Height: 1.5" (38.1 mm)
- ▶ Capacity: 1,000 lbs (453 kg)\*
- ▶ Width: 30" (762 mm)
- ▶ Depth: 26" (660.4 mm)
- ▶ Height: 40" (1.02 m)
- ▶ Weight: 43 lbs (19.5 kg)



Part No.	Description	Replacement Caster Kit
FDD-MD	Universal Drum Dolly for wire packages 25" (635 mm) and under (swivel casters on two wheels)	WWSD-CK
FDD-MD-SW	Universal Drum Dolly for wire packages 25" (635 mm) and under (swivel casters on all wheels)	FDD-CK
FDD-MD-LD	Large Universal Drum Dolly for wire packages 25 – 30" (635 – 762 mm)	FDD-MD-LD-CK
FDSC-13	Heavy Duty Drum Cart — up to 24" Drum Diameter	Contact Customer Support
WWSD	Skid dolly for skids measuring 27" (686 mm) or less	WWSD-CK

\* Heavy duty casters are available for loads over 1,000 lbs (453 kg). Contact Customer Support for more information.

## **DRUM LIFTER** *FDL*

- ▶ Spring loaded clamp design holds drum firmly in place
- ▶ For fiber or steel drums (chimed only)
- ▶ Accepts diameters from 18.5" – 26" (470 mm – 660.4 mm)
- ▶ 1,200 lb (544 kg) capacity

*Note: Drum rim must be within 1" (25.4 mm) of the top of the drum. Content weight must not exceed the drum manufacturers' packing limit. Drums must be closed with lids properly sealed. Not for lifting over 10" (254 mm) high.*



Shown with FDL-FA

## **FORK LIFT ADAPTER** *FDL-FA*

- ▶ Adjustable T-handle keeps adapter from sliding off fork
- ▶ Safety style clasp secures adapter to drum lifter
- ▶ 1,200 lb (544 kg) capacity

## **21" DRUM LIFTER (NON-ADJUSTABLE)** *FDL-21*

- ▶ Our most affordable drum lifter
- ▶ Accepts 20" – 21" (508 – 533 mm) drum diameters
- ▶ 1,200 lb (544 kg) capacity

## **24" DRUM LIFTER (NON-ADJUSTABLE)** *FDL-24*

- ▶ Accepts 23" – 24" (584 – 610 mm) drum diameters
- ▶ 1,200 lb (544 kg) capacity



## **HEAVY DUTY WOOD REEL STAGING CART** *WRSC-HD*

- ▶ Specifically designed to transport wood reels
- ▶ All steel construction built for rugged industrial use
- ▶ Convenient, removable self-storing handle
- ▶ 4" (101.6 mm) Textite swivel and rigid roller bearing casters
- ▶ Locking swivel wheels standard

### **SPECIFICATIONS**

- ▶ Deck Height: 6.75" (171.5mm)
- ▶ Weight: 118 lbs (53.6kg)
- ▶ Dimensions: 36" (914.4mm) H x 36" (914.4mm) L
- ▶ Capacity: 1,200 lbs (544 kg)



DRUM LIFTER LOAD TEST CERTIFICATIONS ARE AVAILABLE ON OUR WEBSITE AT [WIRE-WIZARD.COM](http://WIRE-WIZARD.COM)

# WOOD REEL WIRE DISPENSING

## TRADITIONAL DEREELING ARMS FOR WOOD & PLASTIC REELS

- ▶ Universal base plate designs fit all wood or plastic reels with 1-3/16" (30 mm) or 5" (127 mm) center arbors
- ▶ Ceramic inlet guide provides long wear and prevents wire shaving
- ▶ Twin locking cams secure base plate to reel for stability
- ▶ Easy installation, typically requires little adjustment
- ▶ Outer tube radius and lead will not change wire cast
- ▶ Spring-loaded drag brake provides smooth acceleration and deceleration of feed arm and prevents wire from shingling off reel
- ▶ Large coupler bearing resists both thrust and "G" loads
- ▶ Kits (RW#) include arm, liner, brake, base plate and quick disconnect

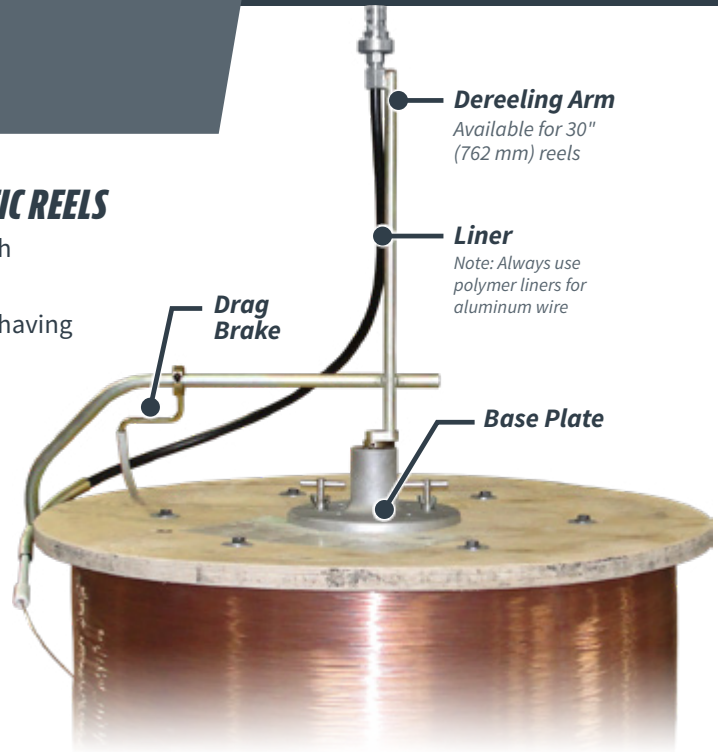

## DEREELING ARMS AND COMPONENTS

Part No.	Description	Reel Diameter	Arbor Hole Size	Liner Type
RW1034-C44	Dereeling Arm Kit for 0.035 – 1/16" (0.9 – 1.6 mm) wire	30" (762 mm)	5" (127 mm)	Steel
RW1034P-C44	Dereeling Arm Kit for 0.035 – 1/16" (0.9 – 1.6 mm) wire	30" (762 mm)	5" (127 mm)	Polymer
RW1034-C37	Dereeling Arm Kit for 0.035 – 1/16" (0.9 – 1.6 mm) wire	30" (762 mm)	1-3/16" (30 mm)	Steel
RW1034P-C37	Dereeling Arm Kit for 0.035 – 1/16" (0.9 – 1.6 mm) wire	30" (762 mm)	1-3/16" (30 mm)	Polymer
RW1028-C44	Dereeling Arm Kit for 1/16" – 5/32" (1.6 – 4 mm) wire	30" (762 mm)	5" (127 mm)	Steel (Large)
RW1028-C37	Dereeling Arm Kit for 1/16" – 5/32" (1.6 – 4 mm) wire	30" (762 mm)	1-3/16" (30 mm)	Steel (Large)
C-44	Base Plate for 5" (127 mm) Arbor Holes	—	5" (127 mm)	—
C-37	Base Plate for 1-3/16" (30 mm) Arbor Holes	—	1-3/16" (30 mm)	—
C-34	Replacement Arm for 30" (762 mm) Reels (steel liner)	30" (76 mm)	—	Steel
C-34P	Replacement Arm for 30" (762 mm) Reels (polymer liner)	30" (762 mm)	—	Polymer
C-28	Large Replacement Arm for 30" (762 mm) Reels	30" (762 mm)	—	—
C-12-12	Replacement drag brake	—	—	—

**Replacement Liners:** C-34-LINER (steel) and C-34P-LINER (polymer) for all RW1034 arms; C-35-LINER (steel) and C-35P-LINER (polymer) for all RW1035 arms; C-28-LINER (steel) for the RW1028 arm.

## BASE PLATES



**Base Plate for 5"  
(127 mm) Arbor Holes  
C-44**

Includes removable insert for National Standard® reels with 3/4" wood



**Base Plate for 1-3/16"  
(30 mm) Arbor Holes  
C-37**

# CONDUIT & CONNECTORS

## ADVANCED POLYMER CONDUIT (see page 14 for Conduit Size Reference Table)

Known throughout the industry for its longevity and low friction coefficient, this durable conduit has proven to outlast metal lined products while still providing much less pull on the feed motor. It's your first choice for stationary or moving feed units and is also the recommended conduit for aluminum wire applications. EC-4-R conduit features an advanced polymer formula for extended wear and durability.

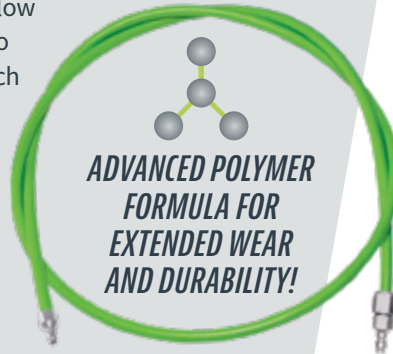

**ADVANCED POLYMER  
FORMULA FOR  
EXTENDED WEAR  
AND DURABILITY!**

**Advanced Polymer Conduit**  
*with connector options*

- ▶ **Available in two sizes:**
  - ▶ EC-4-R for standard wire sizes
  - ▶ EC-5 for large wire
  - ▶ See Conduit Size Reference table on page 14
- ▶ Available in pre-cut lengths with attached self-threading bayonets or in bulk 50', 100', 250' or 500' rolls (15.2 m, 30.5 m, 76.2 m or 152.4 m)
- ▶ Ideal for both ferrous and non-ferrous wire, **required for aluminum wire applications**
- ▶ Recommended for feeding from the source to the weld cell exterior
- ▶ Self threading or compression style connectors available (see page 13)

## QUALITY TESTED FOR MAXIMUM DURABILITY!

We tested the flexural strength of our EC-4-R advanced polymer conduit against a leading competitor by continuously flexing it back and forth until it the point of failure.



*Flexural Strength Testing Device*

**Wire Wizard® polymer conduit survived this rigorous test over 70 TIMES longer than the competitor. The results speak for themselves!**

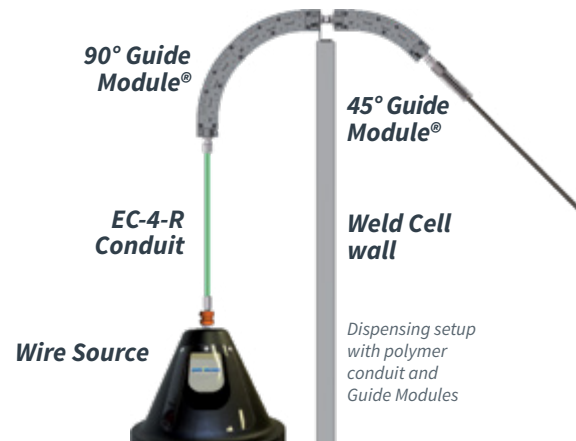

**90° Guide Module®**

**45° Guide Module®**

**EC-4-R Conduit**

**Weld Cell wall**

**Wire Source**

*Dispensing setup with polymer conduit and Guide Modules*

## CONNECTOR OPTIONS & INSTALLATION TOOLS



**Self-threading "screw-on" style fitting**



**Compression style fitting with ferrule**



**Polymer Conduit Cutter EC-CUTTER (see page 43)**



**Polymer Conduit Countersink Tool EC-DB (see page 43)**

Part No.	Conduit Dimensions	Connector Type		Replace Ferrule
		Self Thread	Compression	
EC-4-R*	0.300" ID (7.6 mm) x 0.460 OD (11.7 mm)	A-16F-4	or A-10C-H	A-10CFE
EC-5	0.380" ID (9.6 mm) x 0.600 OD (15.2 mm)	A-16F-5	or A-10R	A-10RFE

\*EC-4-R is cross-linked polymer conduit, ideal for robotic applications.

### EC-4-R PRE-CUT CONDUIT\*

*A-16F-4 Bayonet Attached*

Part No.	Description
EC4-120	120" - 10' (3 m)
EC4-180	180" - 15' (4.6 m)
EC4-240	240" - 20' (6.1 m)
EC4-300	300" - 25' (7.6 m)

### EC-5 PRE-CUT CONDUIT\*

*A-16F-5 Bayonet Attached*

Part No.	Description
EC5-120	120" - 10' (3 m)
EC5-180	180" - 15' (4.6 m)
EC5-240	240" - 20' (6.1 m)
EC5-300	300" - 25' (7.6 m)

### BULK CONDUIT

*In 50', 100', 250' or 500' rolls*

Part No.	Description
EC-4R-	50-B, 100-B, 250-B or 500-B
EC-5-	50-B, 100-B, 250-B or 500-B

\*Custom pre-cut lengths of conduit are available, contact Customer Support for ordering information

## EXTRA FLEXIBLE CONDUIT (see page 14 for Conduit Size Reference Table)

Our most durable conduit displays exceptional wear characteristics and very low friction coefficient. Perfect for robotics, gantry, linear, or any application where a tighter radius is required. Available in pre-cut lengths, 100 ft (30.5 m) bulk coils, or by the foot. All Extra Flexible Conduit now features a spatter-resistant outer jacket, low friction smooth-feed wire coating and patented elliptical wire spring liners.

- ▶ **Available in three sizes:**  
FC-X — standard; FC-XH — heavy duty;  
FC-XH-LW — for large diameter wire
- ▶ FC-X and FC-XH are available in cut lengths with attached bayonets on each end (swaged style)
- ▶ Available in 1 – 100 ft (305 mm – 30.5 m) continuous length coil
- ▶ Compression or swaged style connectors available (see page 13)

Part No.	Conduit Dimensions	Connector / Ferrule
FC-X	0.241 ID (6.1 mm) x 0.500 OD (12.7 mm)	A-10C-X / A-10XFE
FC-XH	0.291 ID (7.4 mm) x 0.610 OD (15.5 mm)	A-10R / A-10RFE
FC-XH-LW	0.390 ID (10 mm) x 0.750 OD (19 mm)	A-9R-HD / A-9R / A-9FE



**Extra Flexible Conduit**  
Shown as cut length with connector options

**CONDUIT COLOR CODING**  
Pre-cut lengths are color-coded as follows:

10' (3 m)	15' (4.6 m)	20' (6 m)	25' (7.6 m)

## STRAIN RELIEF OPTIONS



**Polymer Strain Relief option (-ST)**  
Recommended for light mobility applications



**Steel Strain Relief option (-SR)**  
Recommended for high mobility applications

## SAMPLE CONDUIT RUN

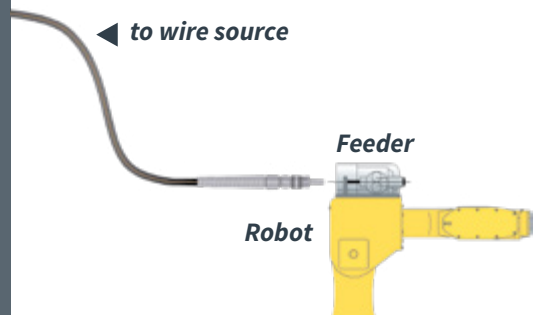

### FC-X PRE-CUT CONDUIT\*

with A-11X Swaged Bayonet

Part No.	Description
FCXS-120	120" – 10' (3 m)
FCXS-180	180" – 15' (4.6 m)
FCXS-240	240" – 20' (6.1 m)
FCXS-300	300" – 25' (7.6 m)

### FC-XH PRE-CUT CONDUIT\*

with A-11XH Swaged Bayonet

Part No.	Description
FCXHS-120	120" – 10' (3 m)
FCXHS-180	180" – 15' (4.6 m)
FCXHS-240	240" – 20' (6.1 m)
FCXHS-300	300" – 25' (7.6 m)

### BULK CONDUIT\*

sold in 100' (30.5 m) sections

Part No.	Description
FC-X-B	100' (30.5 m)
FC-XH-B	100' (30.5 m)
FC-XH-LW-B	100' (30.5 m)

Add **"ST"** to end of part # for polymer strain relief; **"SR"** for steel strain relief.  
For compression fittings on one or both ends, add **-CF** or **-CF2** to the part number.  
\*Custom pre-cut lengths of conduit are available; contact Customer Support for ordering information.

## ELLIPTICAL WIRE LINERS Patented

All Wire Wizard® steel liners featured in our Extra Flexible Conduit and Torch Liners are built with a unique elliptical wire to help eliminate wire shaving and to reduce drag coefficient. To the right are images displaying the difference between Wire Wizard® and a liner manufactured with rectangular wire.

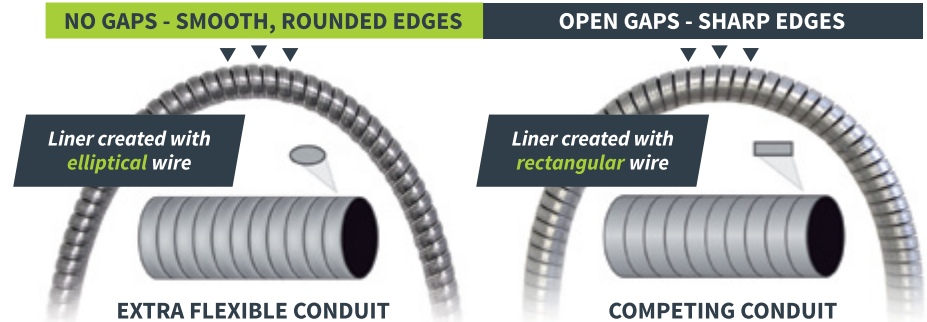

## EXTREME FLEX CONDUIT (see page 14 for Conduit Size Reference Table)

Extreme Flex Conduit is designed for robotic welding applications requiring a high degree of mobility and flexibility. It features the same low friction elliptical wire spring liner as the Extra Flexible conduit, only with a single spatter-resistant outer jacket to provide more flexibility. Extreme Flex conduit is the ideal choice for robotic weld cells with a tight space between the wire source and the robot.

- ▶ Sold by the foot or in pre-cut lengths with attached connectors, fittings adapt to standard Wire Wizard® quick disconnects
- ▶ Suitable for steel wire sizes up to 0.052 (1.3 mm)
- ▶ Polymer strain reliefs included on all standard pre-cut lengths for enhanced strength at connection points

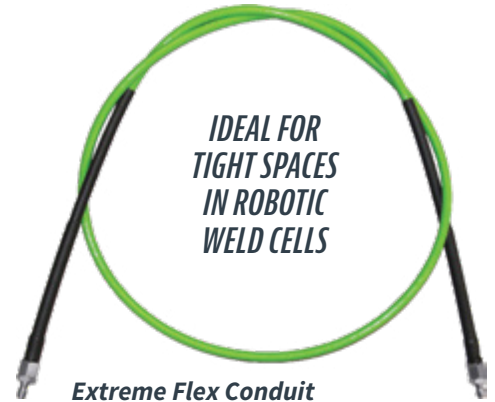

**IDEAL FOR  
TIGHT SPACES  
IN ROBOTIC  
WELD CELLS**

**Extreme Flex Conduit**  
Cut length with connector options

### Compression Connector Assembly

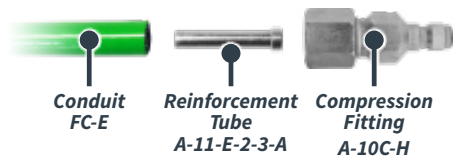

### Pre-Cut Length Assembly



### Conduit (cutaway view) FC-E

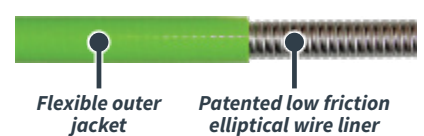

Part No.	Description	Connectors
FC-E	0.241" ID (6.1 mm) x 0.440 OD (11.2 mm)	See below/page 13
FC-E-B	100' (30.5 m) bulk roll	See page 13

Order by length (in feet) for cut lengths without connectors

## SAMPLE CONDUIT RUN

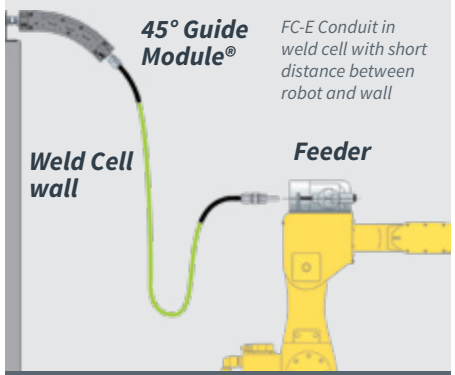

## FC-E CONDUIT CONNECTOR OPTIONS

Connectors not included on lengths ordered by the foot

Part No.	Description
A-10C-H	Compression Fitting with Ferrule
A-10C-H-SR	10.5" Strain Relief and Compression Fitting with Ferrule
A-11E-2-3-A	Reinforcement Tube — required for compression fittings (one per connector)

## FC-E CONDUIT CONNECTOR OPTIONS FOR PRE-CUT LENGTHS

Connectors are included on all pre-cut lengths

### FC-E PRE-CUT CONDUIT FOR STANDARD WIRE WIZARD® DISCONNECTS\*

with A-11E swaged bayonet

Part No.	Description
FCES-120	120" – 10' (3 m)
FCES-180	180" – 15' (4.6 m)
FCES-240	240" – 20' (6.1 m)
FCES-300	300" – 25' (7.6 m)

\*Custom pre-cut lengths of conduit are available, contact Customer Support for ordering information. Add "-SR" for steel spring strain relief on one end, "-SR2" for steel strain relief on both ends.



### Polymer Strain Relief option

Standard on all pre-cut lengths



### Steel Strain Relief option (-SR or -SR2)

Optional Steel Strain Relief

## EXTREME FLEX CONDUIT FOR ALUMINUM WIRE (see page 14 for Conduit Size Reference Table)

Extreme Flex Conduit for Aluminum Wire features a durable advanced polymer liner for smooth wire delivery. Designed for robotic welding applications requiring a high degree of mobility, it features the same low friction elliptical wire spring liner and spatter-resistant outer jacket as the Extreme Flex Conduit for ferrous wires.

- ▶ Provides enhanced strength and durability for robotic applications using aluminum wire
- ▶ Sold in pre-cut lengths with swaged connectors at each end (A-11E)
- ▶ Suitable for aluminum wire sizes up to 1/16" (1.6 mm)
- ▶ Polymer strain reliefs included on all pre-cut lengths for enhanced strength at connection points



**ADVANCED POLYMER LINER FOR ALUMINUM WIRE**

**Extreme Flex Conduit for Aluminum Wire**

*Cut length with connector options*

### Conduit (cutaway view)

FC-E-A

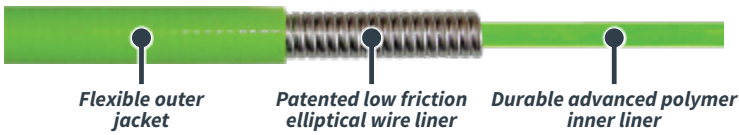

Flexible outer jacket

Patented low friction elliptical wire liner

Durable advanced polymer inner liner

Part No.	Description	Connectors
FC-E-A	0.09 ID (2.3 mm) x 0.440 OD (11.2 mm)	See page 13
FC-E-A-B	100' (30.5 m) bulk roll	See page 13

### Pre-Cut Length Assembly



**Polymer Strain Relief**

*Included on all pre-cut lengths*

*FC-E-A Conduit installed at the wire feeder with a 90° Guide Module and swivel connection*

**90° Mini Guide Module**

## FC-E-A CONDUIT AVAILABLE PRE-CUT LENGTHS

*Connectors are included on all pre-cut lengths*

Part No.	Description
FCES-120-ST-A	120" – 10' (3 m)
FCES-180-ST-A	180" – 15' (4.6 m)
FCES-240-ST-A	240" – 20' (6.1 m)
FCES-300-ST-A	300" – 25' (7.6 m)

## FIGHT WIRE FRICTION WITH WIRE WIZARD® CONDUIT & GUIDE MODULES!

*Wire friction compounds around each bend and turn in the wire delivery system. With low friction EC-4-R or FC-E-A conduit and Wire Guide Modules, friction compounds at less than half the rate it does in applications without Guide Modules. Additionally, the Wire Pilot® Wire Feed Assist can be used with aluminum and other light wires to prevent "bird nesting" at the feeder.*

### COMPOUND FRICTION WITHOUT GUIDE MODULES

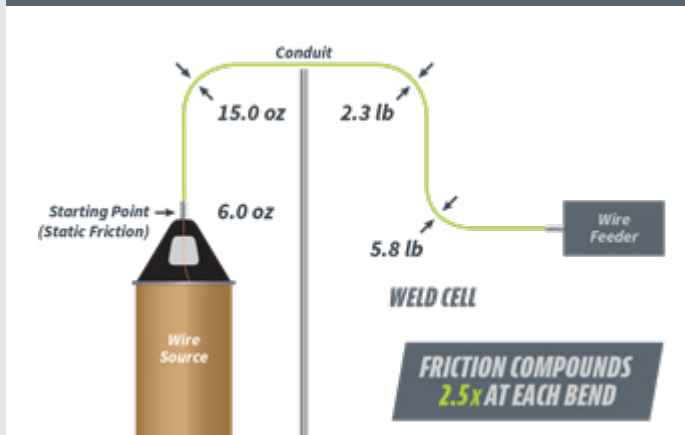

### COMPOUND FRICTION WITH GUIDE MODULES

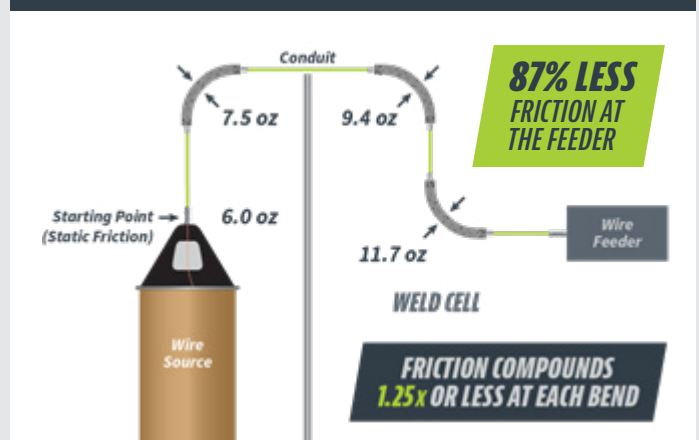

## CONDUIT CONNECTORS

### POLYMER CONDUIT CONNECTORS *Connectors are compression fittings unless otherwise noted*

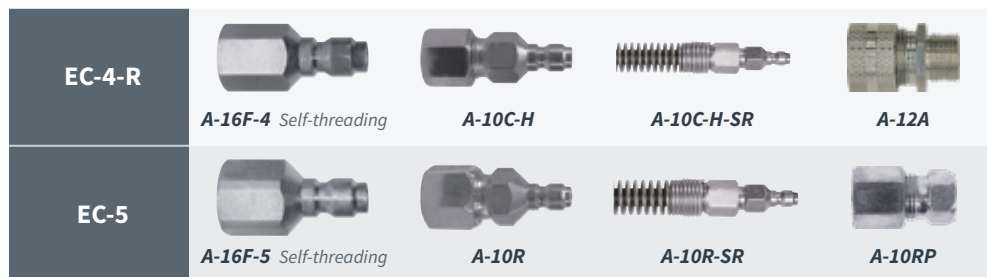

### REPLACEMENT FERRULE

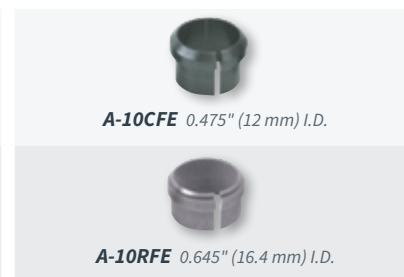

### EXTRA FLEXIBLE CONDUIT CONNECTORS

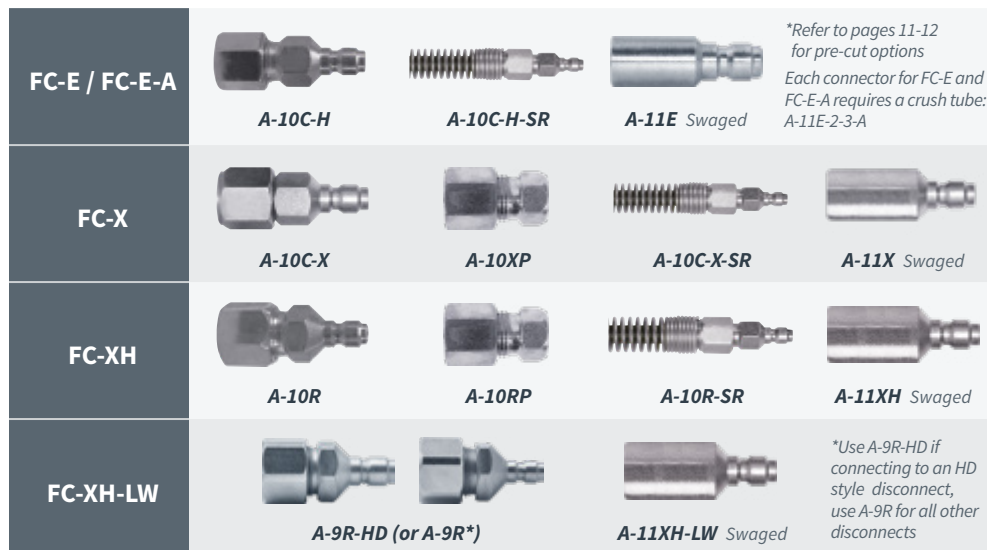

### REPLACEMENT FERRULE



## POLYMER CONDUIT CONNECTORS

### EC-4-R CONNECTORS

Part No.	Description
A-16F-4	Self Threading (1/4" NPT-F) – Steel
A-16F-4B	Self Threading (1/4" NPT-F) – Brass
A-10C-H	Compression (with ferrule)
A-12A	Aluminum Compression Fitting (not a disconnect)
A-10C-H-SR	Strain Relief Connector – 10.5" (267 mm)

### EC-5 CONNECTORS

Part No.	Description
A-16F-5	Self Threading (3/8" NPT-F)
A-10R	Compression (with ferrule)
A-10RP*	Compression (1/4" NPT-F)
A-10R-SR	Strain Relief Connector
A-10R-QD	Connector with Disconnect
A-10R-QD-SR	Strain Relief with Disconnect



Polymer Strain Relief



Steel Spring Strain Relief, 10.5"

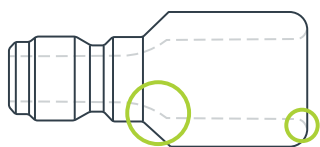

All Wire Wizard® connectors feature rounded shoulders for smooth wire feeding

## EXTRA FLEXIBLE CONDUIT CONNECTORS

### FC-X CONNECTORS

Part No.	Description
A-10C-X	Compression (with ferrule)
A-10XP*	Compression (1/4" NPT-F)
A-10C-X-SR	Strain Relief Connector – 10.5" (267 mm)
A-11X	Swaged Connector

### FC-XH CONNECTORS

Part No.	Description
A-10R	Compression (with ferrule)
A-10RP*	Compression (1/4" NPT-F)
A-10R-SR	Strain Relief Connector
A-11XH	Swaged Connector
A-10R-QD	Connector with Disconnect
A-10R-QD-SR	Strain Relief with Disconnect

### FC-XH-LW CONNECTORS

Part No.	Description
A-9R-HD or A-9R	Compression (with ferrule)
A-11XH-LW	Swaged Connector

NPT – National Pipe Threads | M – Male | F – Female

\* For A-10RP and A-10XP use A-4 quick disconnect

## CONDUIT SIZE REFERENCE TABLE

The table below shows the recommended conduit based on the wire type, size, length of run and application. When choosing the proper conduit, please keep in mind these **seven variables of wire dispensing**:

- ▶ **Type of Wire:** Such as steel, aluminum, cored steel, or silicone bronze
- ▶ **Wire Diameter**
- ▶ **Length of Run**
- ▶ **Wire Cast:** The curvature of one strand of welding wire, measured as the diameter of the circle formed by a strand laying on a flat surface
- ▶ **Wire Helix:** The distance one end of a single wire strand lying on a flat surface rises off that surface (also known as the wire “pitch”)
- ▶ **Application:** Robotic or semi-automatic, number of turns
- ▶ **Drawing Compounds**



		Distance and Recommended Conduit					
		1 – 10 ft (1 – 3 m)		11 – 20 ft (3 – 6 m)		Over 20 ft (6 m)	
Wire Type	Size (inches/mm)	Stationary	Robotic	Stationary	Robotic	Stationary	Robotic
Steel	0.025"/0.6 mm	EC-4-R	FC-X/EC-4-R	EC-4-R	FC-X/EC-4-R	EC-4-R	FC-X/EC-4-R
Steel	0.030"/0.8 mm	EC-4-R	FC-X/EC-4-R	EC-4-R	FC-X/EC-4-R	EC-4-R	FC-X or E/EC-4-R
Steel	0.035"/0.9 mm	EC-4-R	FC-X or E/EC-4-R	EC-4-R	FC-X or E/EC-4-R	EC-4-R	FC-X or E/EC-4-R
Steel	0.040"/1 mm	EC-4-R	FC-X or E/EC-4-R	EC-4-R	FC-X or E/EC-4-R	EC-4-R	FC-X or E/EC-4-R
Steel	0.045"/1.1 mm	EC-4-R	FC-X or E/EC-4-R	EC-4-R	FC-X or E/EC-4-R	EC-4-R	FC-X or E/EC-4-R
Steel	0.052"/1.3 mm	EC-4-R	FC-X or E/EC-4-R	EC-4-R	FC-X or E/EC-4-R	EC-4-R	FC-XH
Steel	1/16"/1.6 mm	EC-4-R	FC-XH	EC-4-R	FC-XH	EC-4-R	FC-XH
Steel	5/64"/2 mm	EC-5	FC-XH	EC-5	FC-XH	EC-5	FC-XH
Steel	3/32"/2.4 mm	EC-5	FC-XH	EC-5	FC-XH	EC-5	FC-XH
Steel	7/64"/2.5 mm	EC-5	FC-XH	EC-5	FC-XH	EC-5	FC-XH-LW
Steel	1/8"/3.2 mm	EC-5	FC-XH-LW	EC-5	FC-XH-LW	EC-5	FC-XH-LW
Steel	5/32"/4 mm	EC-5	FC-XH-LW	EC-5	FC-XH-LW	EC-5	FC-XH-LW
Aluminum	0.025"/0.6 mm	EC-4-R	EC-4-R or FC-E-A	EC-4-R	EC-4-R or FC-E-A	EC-4-R	EC-4-R or FC-E-A
Aluminum	0.030"/0.8 mm	EC-4-R	EC-4-R or FC-E-A	EC-4-R	EC-4-R or FC-E-A	EC-4-R	EC-4-R or FC-E-A
Aluminum	0.035"/0.9 mm	EC-4-R	EC-4-R or FC-E-A	EC-4-R	EC-4-R or FC-E-A	EC-4-R	EC-4-R or FC-E-A
Aluminum	3/64"/1.2 mm	EC-4-R	EC-4-R or FC-E-A	EC-4-R	EC-4-R or FC-E-A	EC-4-R	EC-4-R or FC-E-A
Aluminum	1/16"/1.6 mm	EC-4-R	EC-4-R or FC-E-A	EC-4-R	EC-4-R or FC-E-A	EC-4-R	EC-4-R or FC-E-A
Aluminum	3/32"/2.4 mm	EC-4-R	EC-4-R	EC-4-R	EC-4-R	EC-4-R	EC-4-R
Cored - Steel	0.035"/0.9 mm	EC-4-R/FC-X	FC-X or E/EC-4-R	EC-4-R/FC-X	FC-X or E/EC-4-R	EC-4-R/FC-X	FC-X or E/EC-4-R
Cored - Steel	0.045"/1.1 mm	EC-4-R/FC-X	FC-X or E/EC-4-R	EC-4-R/FC-X	FC-X or E/EC-4-R	EC-4-R/FC-X	FC-X or E/EC-4-R
Cored - Steel	0.052"/1.3 mm	EC-4-R/FC-X	FC-X or E/EC-4-R	EC-4-R/FC-X	FC-X or E/EC-4-R	EC-4-R/FC-X	FC-X or E/EC-4-R
Cored - Steel	1/16"/1.6 mm	EC-5	FC-XH	EC-5	FC-XH	EC-5	FC-XH
Cored - Steel	5/64"/2 mm	EC-5	FC-XH	EC-5	FC-XH	EC-5	FC-XH
Cored - Steel	3/32"/2.4 mm	EC-5	FC-XH	EC-5	FC-XH	EC-5	FC-XH
Cored - Steel	1/8"/3.2 mm	EC-5	FC-XH-LW	EC-5	FC-XH-LW	EC-5	FC-XH-LW
Stainless	0.035"/0.9 mm	EC-4-R	FC-X or E/EC-4-R	EC-4-R	FC-X or E/EC-4-R	EC-4-R	FC-X or E/EC-4-R
Stainless	0.045"/1.1 mm	EC-4-R	FC-X or E/EC-4-R	EC-4-R	FC-X or E/EC-4-R	EC-4-R	FC-X or E/EC-4-R
Stainless	0.052"/1.3 mm	EC-4-R	FC-X or E/EC-4-R	EC-4-R	FC-X or E/EC-4-R	EC-4-R	FC-X or E/EC-4-R
Stainless	1/16"/1.6 mm	EC-5	FC-XH	EC-5	FC-XH	EC-5	FC-XH
Silicon Bronze	0.030"/0.8 mm	EC-4-R	FC-X or E/EC-4-R	EC-4-R	FC-X or E/EC-4-R	EC-4-R	FC-X or E/EC-4-R
Silicon Bronze	0.035"/0.9 mm	EC-4-R	FC-X or E/EC-4-R	EC-4-R	FC-X or E/EC-4-R	EC-4-R	FC-X or E/EC-4-R
Silicon Bronze	0.045"/1.1 mm	EC-4-R	FC-X or E/EC-4-R	EC-4-R	FC-X or E/EC-4-R	EC-4-R	FC-X or E/EC-4-R
Silicon Bronze	1/16"/1.6 mm	EC-5	FC-XH	EC-5	FC-XH	EC-5	FC-XH

**Note:** FC-E Extreme Flex conduit is recommended over FC-X for robotic applications with tight spaces.



# NON-STOP® WIRE DISPENSING SYSTEM

A unique process joins the end wire from a used drum with the start wire of a new full drum. Both butt-welding\* and flash removal operations take only seconds and the two wire ends may be joined during the welding cycle.

- ▶ **Eliminates downtime for wire changeover**
- ▶ No operator action needed — robots can continue to weld while the next full drum is being installed
- ▶ Designed for use with optional **Wire Pilot® Feed Assist and Wire Guide Modules**
- ▶ Works with one or two-station robotic cells (2 or 4 drums)
- ▶ Accepts any bulk wire packaging with the wire end at the top of drum
- ▶ Easy-to-use resistance Butt Welder (welds up to 0.078" / 2 mm wire)
- ▶ Mountable to floor or wall (mounting holes included)
- ▶ Appropriate drum-handling carts available

## SPECIFICATIONS

Dimensions will vary based on drum size

- ▶ **2 Drum Unit:** 47" W x 29" D x 7' H (1.2 m W x 0.74 m D x 2.13 m H)
- ▶ **4 Drum Unit:** 47" W x 55" D x 7' H (1.2 m W x 1.4 m D x 2.13 m H)

\* Wire manufacturer must present wire end at top of dispensing drum to butt weld beginning and ending of wires. Call Customer Support for information.



## ACCESSORIES

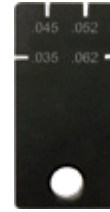

### Wire Gauge Block WGB

For 0.035", 0.045", 0.052", and 0.062" wire (included with docking station)



### Wire Parters BW-WP

Leaves flat wire ends for easy butt-welding



### Wire Sizer Order by wire size

Removes burr in wire joint for smooth feeding



### Non-Stop® Wire Dispensing System with two stations NSW-20.4F-18-B2

Shown with optional Butt Welder Docking Station. Docking Station includes Butt Welder, Wire Parters and Wire Gauge Block. Wire Sizer sold separately.

## NON-STOP® WIRE DISPENSING SYSTEMS & ACCESSORIES

Part No.	Description
NSW-20.4F-18B-2	2-Station System for 20.4" (518 mm) Ø Drums (1-Torch)
NSW-20.4F-18B-4	4-Station System for 20.4" (518 mm) Ø Drums (2-Torch)
NSW-23.1F-18B-2	2-Station System for 23.1" (587 mm) Ø Drums (1-Torch)
NSW-23.1F-18B-4	4-Station System for 23.1" (587 mm) Ø Drums (2-Torch)
NSW-26F-18B-2	2-Station System for 26" (660 mm) Ø Drums (1-Torch)
NSW-26F-18B-4	4-Station System for 26" (660 mm) Ø Drums (2-Torch)
NSW-SC24-18B-2	2-Station System for 1,000 lb (453 kg) Accu-Pak Drums (1-Torch)
NSW-SC24-18B-4	4-Station System for 1,000 lb (453 kg) Accu-Pak Drums (2-Torch)
NSW-OC23.5-18B-2	2-Station System for 23.5" (597 mm) Octagon Drums (1-Torch)
NSW-OC23.5-18B-4	4-Station System for 23.5" (597 mm) Octagon Drums (2-Torch)
NSW-1-2-29-18B	2-Station System for 29" (737 mm) Square Drums (1-Torch)
WGM-NSW-SW-18	Wire Guide Module® Swivel Kit Adapter (allows 360° rotation)
NSW-BW-DS-R13	Butt Welder Docking Station (110 V)

Part No.	Description
NSW-BW-DS-220EU-R13	Butt Welder Docking Station (220 V European)
NSW-BW-WS-035	Wire Sizer for 0.035" (0.9 mm) wire*
NSW-BW-WS-040	Wire Sizer for 0.040" (1.0 mm) wire*
NSW-BW-WS-045	Wire Sizer for 0.045" (1.2 mm) wire*
NSW-BW-WS-052	Wire Sizer for 0.052" (1.3 mm) wire*
NSW-BW-WS-062	Wire Sizer for 0.062" (1.6 mm) wire*
NSW-BW-WS-078	Wire Sizer for 0.078" (2 mm) wire*
NSW-BW-WS-1	Wire Sizer without dies* (must specify wire size when ordering)
BW-WP	Wire Parters (included on butt welder docking station)
WGB	Wire Gauge Block (included on butt welder docking station)
NSW-PFA-AK-13	Wire Pilot® Feed Assist Mounting Adapter (includes liner)
NSW-BLA	Drum alignment locator with drum straps

\* Wire Sizer replacement dies available. Contact Customer Support for more information.

# NON-STOP®

WIRE DISPENSING

**ELIMINATES  
DOWNTIME FOR WIRE  
CHANGEOVER!**

**ADDITIONAL WIRE  
EXIT POINT OPTIONS**



NSW-PFA-AK-13



**Guide  
Module®(s)**

May be mounted in a fixed position or with the Guide Module® Swivel Kit to allow 360° rotation

NSW  
Drum  
Hoods

Wire  
Whip

Wire  
Transfer  
Arm

Butt Welder  
Docking  
Station

**DRUM SETUP**



Single Torch Unit  
(with round drums)

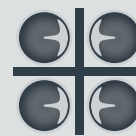

2-Torch Unit  
(with round drums)

**DRUM 1**

**DRUM 2**

Start  
Wire

Start  
Wire

End  
Wire



1  
Join the end wire from drum 1 with the start wire from drum 2 using the Butt Welder.



2  
Remove the flash in the wire joint using the Wire Sizer (sold separately) or rotary tool with stone bit.



3  
Position the wire on the pathway between the two drums.

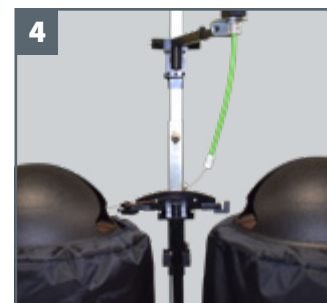

4  
When wire from drum 1 runs out, the transfer arm will switch over to drum 2. Simply replace empty drum and repeat steps 1 - 3.

# WIRE WIZARD® GUIDE MODULE® SYSTEM

## GUIDE MODULE®

### THE NEW PATH OF LEAST RESISTANCE!

The innovative **Wire Wizard Guide Module® System** utilizes a series of rollers with bearings to allow the weld wire to “coast” around bends and corners in the conduit, eliminating the points of high friction that occur in these areas. By eliminating the friction on the wire, it eliminates arc failures, improves consistency and enables considerably longer conduit runs of 100 feet or more, allowing wire packages to be centrally located. Each 45° Guide Module® may be connected to additional modules to form turns of 90°, 135° or 180° within the wire dispensing system. Compatible with ferrous and non-ferrous wires. Patented design.

- ▶ **Eliminates skid friction** on the wire in areas where bends/corners are necessary throughout the wire dispensing system
- ▶ Smooth, low friction wire feeding **improves consistency of welds, eliminates arc failures and reduces downtime**
- ▶ **New and improved design** with removable quick access panel for easy maintenance
- ▶ **Turns POUNDS of pull force at the feeder into OUNCES!**
- ▶ Considerably less expensive than alternative methods of eliminating friction on wire over long distances
- ▶ Allows long distance conduit runs of 100 feet + (30.5 m +)
- ▶ Increases life of conduit and consumables by reducing friction
- ▶ Saves floor space by allowing wire packages to be located closer to the cell wall
- ▶ 45° modules may be connected together to form a 90° turn, 135° turn, 180° turn

### INTERNAL VIEW

Lightweight durable polymer body

Heavy duty rollers with bearings

Wire from source

Cell wall mounting kit

Conduit connection going to feeder



Installation with 90° Guide Modules and Non-Stop® Wire Systems

### Four Models Available to Cover Virtually all Welding Applications:

- ▶ **Standard Guide Module®:** For solid wires 0.035 – 5/64" (0.9 – 2 mm).
- ▶ **90° Mini Guide Module®:** For solid wires up to 0.052 (1.3 mm), compact size for tight 90° turns.
- ▶ **Heavy Duty Guide Module® HD\*:** For cored and stainless steel wires 0.035 – 5/64" (0.9 – 2 mm). Includes heavy duty steel rollers.
- ▶ **Large Guide Module® XL\*:** Compatible with large wire 3/32" – 5/32" (2.4 – 4 mm). Ideal for SAW welding applications! See Submerged Arc catalog for details.
- ▶ **3 YEAR GUARANTEE!** With proper maintenance and installation. Excludes damage caused by industrial contaminants.

▶ WATCH VIDEO



SEE PAGES 20 & 21 FOR GUIDE MODULE® COMPONENTS & ACCESSORIES

## STANDARD GUIDE MODULE® PARTS & ACCESSORIES

Part No.	Description
WGM-1	Guide Module®, Single 45° (for wire up to 5/64" / 2 mm)
WGM-1-S	Guide Module® HD, Single 45° (for stainless/cored wire up to 5/64" / 2 mm)
WGM-M-1	Guide Module® Mini 90°, Single 90° (for wire up to 0.052/1.3 mm)
WGM-ECK-50	Guide Module® End Cap Kit 1/2" NPS-F (for A-10HM or WGM-A5)
A-10HM	Guide Module® Conduit Connector for EC-4-R Conduit
A-10XM	Guide Module® Conduit Connector for FC-X Conduit
WGM-A5	Guide Module® Insulated Connector with Quick Disconnect
WGM-DP-LW	Guide Module® Direct Pull Inlet (includes ceramic inlet guide)
WGM-021	Guide Module® Support Bracket
WGM-024	Guide Module® Support Bracket with Slotted Holes
WGM-025	Guide Module® 45° Angle Support Bracket
WGM-044	Guide Module® Weld-on or Bolt-on Support Bracket
WGM-049-L	Guide Module® Quick Disconnect Adapter (male end)
WGM-SMB-3	Guide Module® Bracket for Stacking/Mounting up to 3 Guide Modules
WGM-1-90-BRKT	Guide Module® 90° Hanging Bracket Kit
WGM-1-BRKT	Guide Module® 45° Hanging Bracket Kit
WGM-A-10BK	Guide Module® Face Mount Bracket with nut for A-10HM
WGM-2-BRKT	Guide Module® Insulated Face Mount Bracket with nut and insulators for A-10HM
WGM-3-BRKT	Guide Module® Side Mounting Bracket for Attachment to the WGM-PFA-STAND
WGM-DK	Guide Module® Drum Mounting Kit for use with Wire Wizard® Hoods
WGM-CM-1	Guide Module® 2 – 13" (51 – 330 mm) Adjustable Extension Arm with Adjustable Length and Height
WGM-EA-10	Guide Module® 10" (254 mm) Adjustable Extension Arm with Hinge Point

Part No.	Description
WGM-EA-20	Guide Module® 20" (508 mm) Adjustable Extension Arm with Hinge Point
WGM-FSK-L	Guide Module® Swivel Kit for Direct Connection to Lincoln Electric® Series 10 Feeder
WGM-FSK-P	Guide Module® Swivel Kit for Direct Connection to Panasonic®/OTC® Feeders (9/16-18 F thread)
WGM-FSK-14	Guide Module® Swivel Kit with Male Fitting for Other Feeders/Female Disconnects
WGM-MSK-14	Guide Module® Swivel Kit for Connecting Stationary to Swiveling Guide Modules
WGM-SW-BM	Guide Module® Bracket Mounted Swivel Kit (swivel with WGM-A-10BK style bracket)
WGM-FLM	Guide Module® Floor Mounting Bracket
WGM-1K	Guide Module® Feeder Inlet Mounting Kit
WGM-LBM-BRKT	Guide Module® L-bracket Mounting Kit
WGM-UAK	Guide Module® Union Adapter Kit (washer and bracket mounts)
WGM-WK-1-1	Guide Module® Wall Mount Kit, Single Sided
WGM-WK-1-3	Guide Module® Adjustable Wall Mount Kit for up to 3" (76 mm) thick walls, Single Sided
WGM-WK-2-1	Guide Module® Wall Mount Kit, Double Sided
WGM-RSK-16	Guide Module® Roof Mount or Wall Mount Swivel Kit – includes 90° Compact Module
WGM-PFA-STAND	Adjustable Drum/Reel Stand for Guide Modules, 50" – 90" H (1270 – 2286 mm); includes one Arm Assembly
WGM-STAND-SW-14	Guide Module® Swivel Kit for WGM-PFA-STAND
GC-1	Wire Guide Caps for up to 0.052 wire (required for cored wire) - 100/pack
GC-2	Wire Guide Caps for up to 0.062-3/32 wire (required for cored wire) - 100/pack
GC-CRIMPER	Crimping tool for installation of wire guide caps

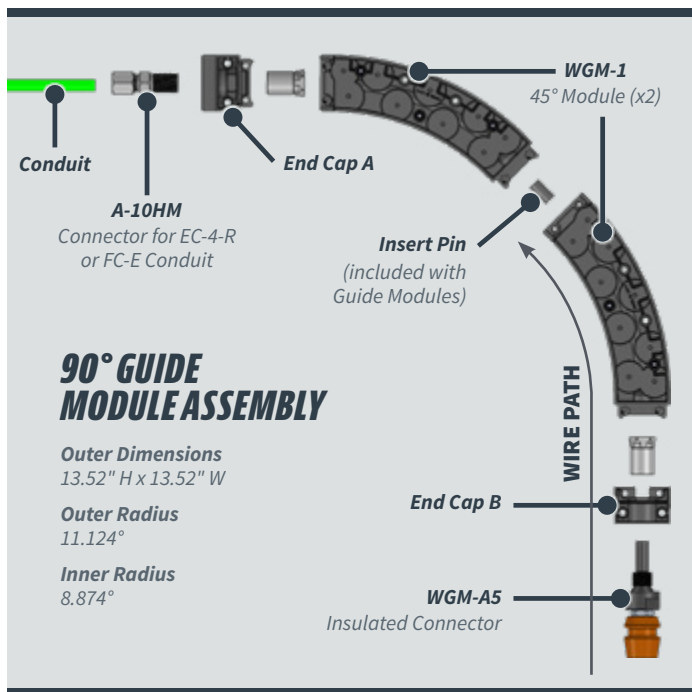

### ROOF SWIVEL KIT

- ▶ Allows 360° rotation from weld cell roof or wall
- ▶ Includes WGM-C-1 Compact 90° Guide Module®



### WIRE GUIDE CAPS

Guide caps are easily crimped on wire ends for smooth feeding of wire through the wire delivery system. Required for cored wire applications.

- ▶ GC-CRIMPER Crimper for Wire Guide Caps
- ▶ GC-1 Guide cap for up to 0.052 wire
- ▶ GC-2 Guide cap for 0.062 – 0.078 wire
- ▶ Guide Caps sold 100 per pack



## COMPONENTS & MOUNTING ACCESSORIES

### 45° WIRE GUIDE MODULES

**WGM-1**  
For solid wire up to 5/64" (2 mm)

**WGM-1-S**  
For cored and stainless wire up to 5/64" (2 mm)

**WGM-LW-1**  
For large wire 3/32" - 5/32" (2.4 mm - 4 mm)



### 90° MINI GUIDE MODULE®

|- - -6" (152 mm) - - -|

Allows tight 90° turns for solid wires up to 0.052 (1.3 mm)

**WGM-M-1**  
Uses same end caps as WGM-1



### END CAP CONNECTORS

Each kit includes one A and one B end cap

**End Cap A**

**WGM-ECK-50**  
Use for WGM-1, WGM-1-S and WGM-M-1

**End Cap B**

**WGM-LW-ECK-50**  
For WGM-LW-1

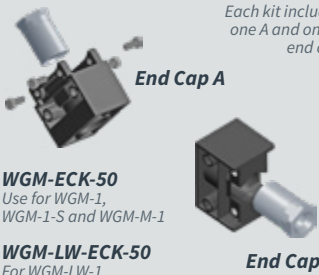

### FACE MOUNT BRACKET KIT

**ALLOWS 360° DIRECTIONAL ADJUSTMENT**

**WGM-A-10BK**  
Add WGM-A5 or order WGM-2-BRKT for insulated connections



### CONDUITS & FITTINGS

**EC-4-R** (7.6 mm I.D.)  
Fittings: A-16F-4 or A-10C-H

**EC-5** (10.2 mm I.D.)  
Fittings: A-16F-5 or A-10R

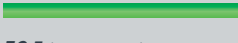

### WIRE WIZARD® POLYMER CONDUIT

**A-16F-#** Screw-on Fitting

**WGM-A5** All modules except WGM-LW-1

**Guide Module® End Cap**

**A-10HM** for EC-4-R

**A-10##** Compression

**Quick Disconnect A-5** with WGM insert

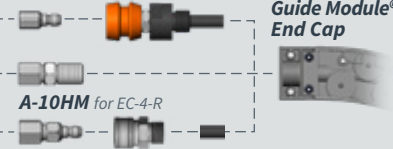

### CONDUITS & FITTINGS

**FC-X** (6.1 mm I.D.)  
Fitting: A-10C-X with WGM-A5  
A-10XM without WGM-A5

**FC-XH** (7.4 mm I.D.)  
Fitting: A-10R

**FC-XH-LW** (10 mm I.D.)  
Fitting: A-9R-HD (with A-5HD)  
A-9R (without A-5HD)



### WIRE WIZARD® EXTRA FLEXIBLE CONDUIT

**A-10##** Compression

**WGM-A5** All modules except WGM-LW-1

**Guide Module® End Cap**

**Swaged Fitting** (pre-cut only)

**A-9R-HD** Quick Disconnect A-5HD for WGM-LW-1 only

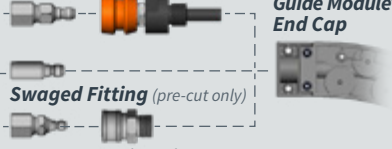

### CELL WALL MOUNTING KIT

**SINGLE-SIDED**

**WGM-WK-1-1**



### CELL WALL MOUNTING KIT

**DOUBLE-SIDED**

**WGM-WK-2-1**



### ADJUSTABLE WALL MOUNT BRACKET

**WGM-WK-1-3**  
Adjustable for up to 3" (76 mm) thick walls



### FLOOR MOUNTING BRACKET

**WGM-FLM**  
Modules may be attached to one or both sides

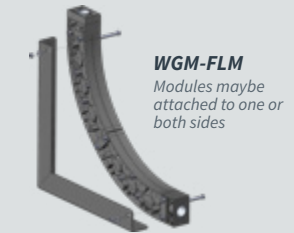

### GUIDE MODULE® STAND

**FOR DRUM OR WOOD REEL APPLICATION**

**Optional swivel with 90° module**

**Direct Pull Kit WWDP**

**WGM-A-10BK**

**Wire Pilot® Feed Assist option**

**Wire Spool option WGM-PFA-STAND-SPOOL**

Adjustable height from 50" - 86" (1.3 - 2.2 m)

Adjustable arm length from 4" - 19" (102 - 483 mm)

Drum or Wood Reel

**Guide Module® Stand WGM-PFA-STAND**  
Includes stand and one adjustable extension arm



### GUIDE MODULE® STAND FOR MEZZANINE APPLICATION

**FOR APPLICATIONS WHERE WIRE SOURCE IS ABOVE WELD CELL**

**Side Mount Bracket WGM-3-BRKT**

**Direct Pull Kit WWDP**

**Conduit to wire feeder**

**Additional Arm WGM-PFA-STAND-ARM**

**Guide Module® Stand WGM-PFA-STAND**  
Includes stand/one adjustable arm

Adjustable height from 50" - 86" (1.3 - 2.2 m)

Adjustable arm length from 4" - 19" (102 - 483 mm)

Drum or Wood Reel

Wire Wizard® Fire Resistant Drum Covers and Dollies Available



### L-BRACKET MOUNTING KIT

**WGM-LBM-BRKT**



### 360° UNION ADAPTER KIT

**ALLOWS DUAL 360° DIRECTIONAL ADJUSTMENT**

**WGM-UAK**  
Includes Bracket

Union kit assembly



## THE NEW PATH OF LEAST RESISTANCE!

<b>CONDUIT CONNECTOR OPTIONS</b> <b>THREADED CONNECTORS</b>  <p><b>A-10HM</b> For connecting EC-4-R or FC-E to WGM-1, WGM-1-S or WGM-M-1; use A-10XM for FC-X</p> <p><b>A-9R or A-9R-HD</b> For connection FC-XH-LW to WGM-LW-1</p> <b>DETACHABLE QD CONNECTORS</b>  <p><b>WGM-A5</b> Insulated connector with quick disconnect</p> <p>Use for WGM-1, WGM-1-S and WGM-M-1</p> <p><b>A-5HD</b> QD for WGM-LW-1 Requires HD fittings</p>		<b>INSULATED FACE MOUNT BRACKET</b>  <p>ALLOWS 360° DIRECTIONAL ADJUSTMENT</p> <p><b>WGM-2-BRKT</b></p>	<b>DRUM HOOD MOUNTING KIT</b>  <p><b>WGM-DK</b></p>	<b>DIRECT PULL INLET</b>  <p><b>WGM-DP-LW</b> Includes ceramic inlet – will not shave wire</p>
<b>BRACKET MOUNTED SWIVEL KIT</b>  <p>Module Connection</p> <p><b>WGM-SW-BM</b> Includes WGM-A-10BK style bracket</p>	<b>HOOD SWIVEL KIT</b>  <p>Allows 360° rotation on top of drum cover.</p> <p><b>WGM-HSK-15</b></p>	<b>MODULE / FEEDER SWIVEL KITS</b>  <p><b>WGM-FSK-14</b> Swivel Kit with Male Fitting for other feeders/ female disconnects</p> <p><b>WGM-FSK-L</b> Swivel for Lincoln Electric® Series 10 style feeders (includes inlet guide)</p> <p><b>WGM-FSK-P</b> Swivel for most Panasonic/OTC feeders (9/16-18 F thread)</p> <p><b>WGM-MSK-14</b> Creates 360° rotation point between two modules</p>		<b>FEED ASSIST SWIVEL KIT</b>  <p><b>WGM-PFA-SW</b> for the Wire Pilot® Feed Assist</p> <p><b>WGM-PFA-AK</b> for fixed mount (standard modules) or PFA-54 for WGM-LW-1</p>
<b>MALE DISCONNECT FITTINGS</b>  <p><b>WGM-049-L</b> Male fitting for WGM-1, WGM-1-S and WGM-M-1</p> <p><b>WGM-LW-049</b> Fitting for WGM-LW-1</p>	<b>HANGING BRACKET KITS</b>  <p><b>WGM-1-BRKT</b> 45° Hanging Bracket Kit</p> <p><b>WGM-1-90-BRKT</b> 90° Hanging Bracket Kit WGM-LW-BRKT for WGM-LW-1</p>		<b>STACKABLE BRACKET</b>  <p>ALLOWS MOUNTING OF UP TO THREE STACKED MODULES</p> <p>Stackable Bracket</p> <p><b>WGM-SMB-3</b></p>	<b>FEEDER INLET MOUNT KIT</b>  <p>MOUNTS TO FEEDER THROUGH BRACKET OR PANEL</p> <p><b>WGM-IK</b> Excludes bracket</p> <p>Sample installation on bracket</p>
<b>ADJUSTABLE EXTENSION ARM</b> <b>FOR INSTALLATION AT THE TOP OF THE WELD CELL WALL</b>  <p><b>WGM-CM-1</b> Extends 2" (51 mm) – 13" (330 mm), adjustable height up to 6.5" (165 mm)</p> <p>Conduit and fittings sold separately</p>	<b>PIVOTING ADJUSTABLE EXTENSION ARMS</b> <b>BOTH ARMS PIVOT UPWARD TO ALLOW EASY WIRE FEEDING FROM DRUMS AND REELS</b>  <p><b>WGM-EA-10</b> Extends 10" (254 mm) – 18" (457 mm)</p> <p><b>WGM-EA-20</b> Extends 20" (508 mm) – 36" (914 mm)</p> <p>Conduit and fittings sold separately</p>		<b>TURN TABLE MODULE ADAPTER</b>  <p>SECURES MODULES TO WIRE WIZARD® TURN TABLE</p> <p><b>WGM-4-BRKT</b> Compatible with WGM-1, WGM-1-S and WGM-LW-1</p>	
<b>WELD-ON OR BOLT-ON MOUNTING BRACKET</b>  <p><b>WGM-044</b></p>	<b>SUPPORT BRACKET</b>  <p><b>WGM-021</b></p>	<b>SLOTTED SUPPORT BRACKET</b>  <p><b>WGM-024</b></p>	<b>45° ANGLE SUPPORT BRACKET</b>  <p><b>WGM-025</b></p>	

## GUIDE MODULE® SYSTEM SAMPLE APPLICATIONS

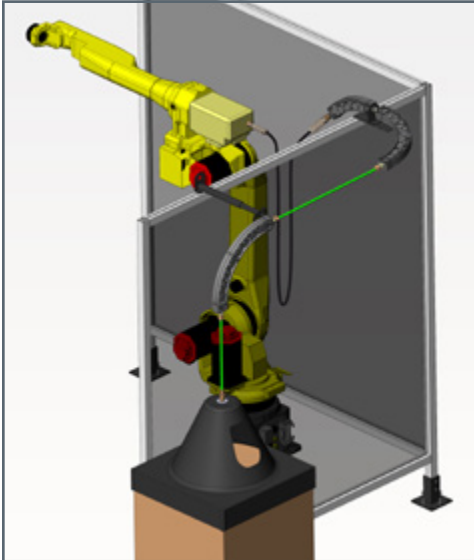

Setup with Modules mounted on top of cell

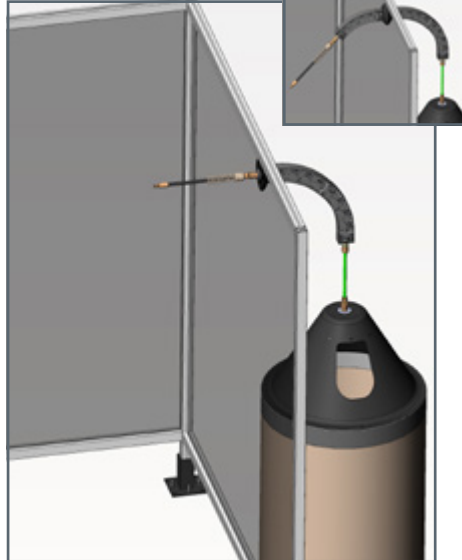

Setup with Modules mounted on cell wall, saving valuable floor space



180° Modules installed on cell with two robots and the Non-Stop® Wire Dispensing System



## GUIDE MODULE® FLEX



### **ELIMINATES EXCESS WIRE FRICTION IN HIGH MOBILITY WELDING APPLICATIONS!**

Featuring the same innovative concept as the fixed radius Wire Wizard® Guide Modules, the **Guide Module® FLEX System** is designed especially for welding applications using a traversing axis, gantry or boom. The FLEX utilizes a series of rollers with bearings to eliminate skid friction on the wire, providing a smooth, consistent wire feed. Externally or internally mountable to select igus® e-chain® cable carrier systems. **Standard FLEX Modules** compatible with solid wires (ferrous or non-ferrous) 0.035 to 1/16" (0.9 – 1.6 mm).

**Large FLEX Modules** compatible with steel wire 1/16" to 5/32" (1.6 – 4 mm), ideal for SAW applications. Patent pending design. See Submerged Arc catalog for more details.

*Guide Module® FLEX system installed on igus® e-chain® cable carriers in a traversing robotic application.*

**ONLY 6 OZ OF PULL FORCE ON APPLICATION WITH  
40 FT (12.2 M) OF CONDUIT & FLEX MODULES!**

*Pull test measured at the wire feeder with a delivery system consisting of 0.035 steel wire, 20 feet of EC-4-R conduit, and a 20 foot section of FLEX Modules.*

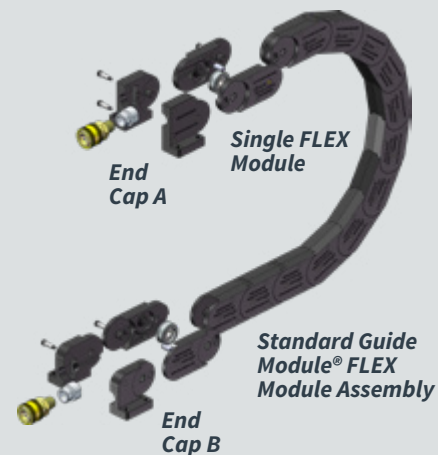

## STANDARD GUIDE MODULE® FLEX PARTS & ACCESSORIES

Part No.	Description
WGM-F-2-5	Guide Module® FLEX 5 ft (1.5 m) Section — requires end caps
WGM-F-2-10	Guide Module® FLEX 10 ft (3 m) Section — requires end caps
WGM-F-2-M	Guide Module® FLEX Individual Module (for custom lengths, approx. 6 = 1 ft)
WGM-F-2-ECK	Guide Module® FLEX End Cap Kit — includes both End Caps
WGM-F-2-017	Guide Module® FLEX Aluminum Mounting Channel, 4 ft (1.2 m) section
WGM-F-2-SK	Splice Kit for Connecting Mounting Channels
WGM-F-2-MK	End Cap Mounting Kit for Connecting FLEX Modules at the end of the channel
WGM-F-2-ECK-ADP	Adapter for Connecting WGM-F-2 FLEX to Stationary Guide Modules
WGM-SB-1	Mounting brace for single FLEX connection to WGM-M-1 Modules
WGM-SB-3	Mounting brace for three FLEX connections to WGM-M-1 Modules

Additional lengths, sizes and components may be available, contact Customer Support or see website for details

## GUIDE MODULE® FLEX DIMENSIONS

Use dimensions noted to determine length required for your application

### STANDARD GUIDE MODULE® FLEX LINK & END CAP DIMENSIONS

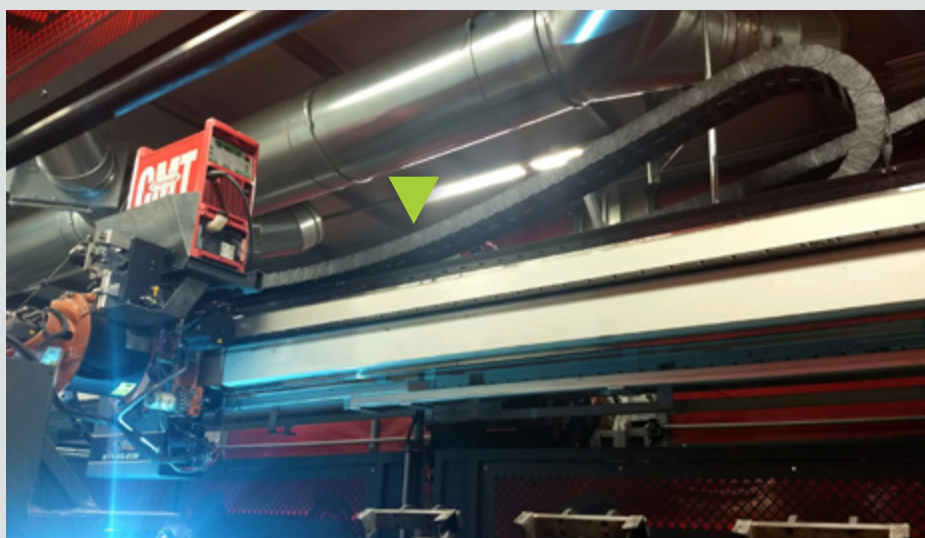
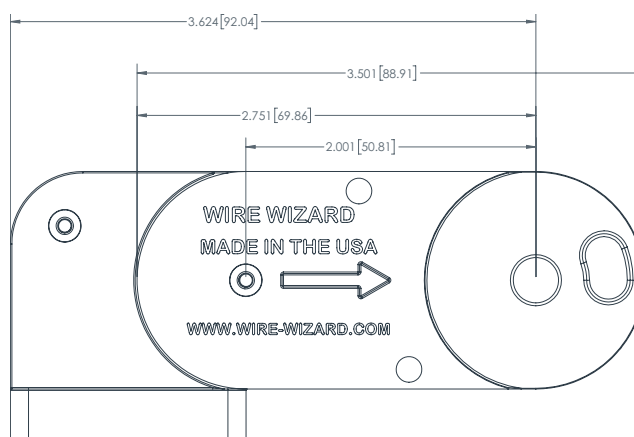

FLEX Modules installed inside an igus® cable carrier with robot mounted on a linear track. Photo courtesy of PA Robotics.

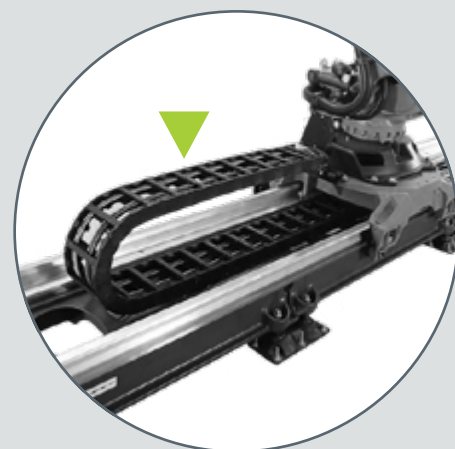

Guide Module® FLEX installs internally or externally to select robotic cable carriers for smooth wire delivery.

# WIRE STRAIGHTENERS

Wire Wizard® manufactures four models of wire straighteners that can be used to straighten or recast all types of wire. The main body is constructed of aluminum, making our straighteners some of the lightest in the market. All models are equipped with a locating calibration on the face of the unit and a fine adjustment scale on the tension knob. This results in an extremely fast and accurate setting of wire cast. Our full range of fittings and inlet guides guarantee a trouble-free fit for any application.

## INSULATED MOUNTING KITS

Available for all models

- WSS-100-IK**  
Small
- WSM-100-IK**  
Medium
- WSL-100-IK**  
Large

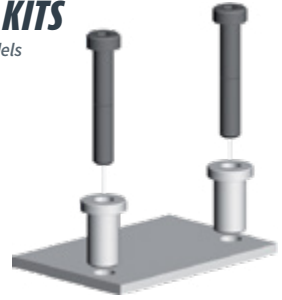

## SMALL WIRE STRAIGHTENERS

**WSS-100 and WSS-100-A**  
For wire sizes 0.035 – 0.062  
(Order **WSS-100-A** for aluminum wire)

- ▶ Dimensions: 3.74" W x 3" H x 1.63" D (95 mm W x 78 mm H x 41.3 mm D)
- ▶ Weight: 1 lb (0.45 kg)



**WSS-100**  
U-Groove Drive Rolls for steel wire

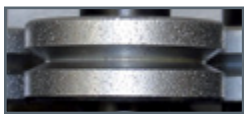

**WSS-100-A**  
V-Groove Drive Rolls for aluminum wire

### NON-THREADED FITTINGS\*

#### STEEL WIRE

Connection to disconnect, on feeder or in-line



**A-1QD-12**

#### ALUMINUM WIRE

Connection to disconnect, on feeder or in-line



**A-1QD-5/32 and A-4L-H liner**

#### STEEL OR ALUMINUM WIRE



Wire



End View



**A-1C-S**

Delrin with ceramic inlet

\* Fittings may be used as inlets or outlets depending on setup



**Steel Wire Straightener WSS-100**

- or -  
**Aluminum Wire Straightener WSS-100-A**

### THREADED FITTINGS\*

#### STEEL WIRE



**A-1LN-S-12**



**A-3**  
Quick Disconnect

#### ALUMINUM WIRE



**A-1LN-S-5/32 and A-4L-H liner**



**A-3**  
Quick Disconnect

**A-1H-B**

Adapter for dual wire straighteners

Replacement Wheel Kits: **WSS-100-WHEEL** (standard) or **WSS-100-A-WHEEL** (aluminum wire model)

## MEDIUM WIRE STRAIGHTENER

**WSM-100**  
For wire sizes 0.062 – 3/32" (1.6 – 2.4 mm)

- ▶ Dimensions: 5.71" W x 3.34" H x 1.875" D (145 mm W x 84.7 mm H x 47.63 mm D)
- ▶ Weight: 1.75 lbs (0.8 kg)

### FITTINGS FOR WSM-100

Order **A-1LN-K** for Inlet/Outlet Kit (includes two A-1LNs)



**A-16M-ST**  
Attaches to QD

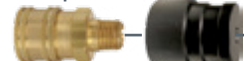

**A-4**

Quick Disconnect

**A-1LN**

Inlet Guide



#### LWS-1

Adapter for connection to Lincoln Feeder or to combine two WSM-100 Straighteners

Replacement Wheel Kit: **WSM-100-WHEEL**

## LARGE WIRE STRAIGHTENER

**WSL-100**  
For wire sizes 3/32 – 5/32" (2.4 – 4 mm); ideal for heavy duty SAW applications

- ▶ Dimensions: 8.66" W x 4.09" H x 2.25" D (220 mm W x 103.8 mm H x 57.2 mm D)
- ▶ Weight: 4 lbs (1.8 kg)

### FITTINGS FOR WSL-100

Order **A-1LN-K-LW** for Inlet/Outlet Kit (includes two A-1LN-LWs)



**A-16M-ST-HD**  
Attaches to QD



**A-4HD**

Quick Disconnect Requires HD male fittings

**A-1LN-LW**

Inlet Guide

#### WS-10S

Outlet Adapter for Lincoln Electric Feeder models 10S, NA-3 and NA-5. Includes ceramic inlet.



#### LWS-1

Adapter for combining two WSL-100 Straighteners

Replacement Wheel Kit: **WSL-100-WHEEL**

# WIRE PILOT® FEED ASSISTS

## WIRE PILOT® PNEUMATIC WIRE FEED ASSIST

The Wire Pilot® Pneumatic Feed Assist provides an economical way to help the wire feeder move wire through the conduit in applications where there must be minimal friction, travel a long distance or where the workload on the wire feeder must be reduced. When combined with Guide Modules, it allows the ultimate flexibility when it comes to wire delivery and **wire packages can be located 150 ft (46 m) or more away from the arc.** Using only compressed air, the Feed Assist easily relieves several pounds of pulling force from the feed motor. Adjustable torque setting **prevents "bird nesting,"** commonly occurring in aluminum or light wire applications. Compatible with ferrous and non-ferrous wire. Patented design.

- ▶ **Eliminates drag coefficient inside the conduit**
- ▶ Provides "Push-Pull" system to get wire from source to the feeder
- ▶ Extends conduit life and increases arc-on time
- ▶ Enables longer conduit runs (150 ft/46 m+), enabling centrally located wire packages as well as allowing the use of bulk wire in many applications that would normally require small spools
- ▶ Prevents burn backs caused by wire feeding problems
- ▶ Solves many feeding issues with large diameter wire used for SAW

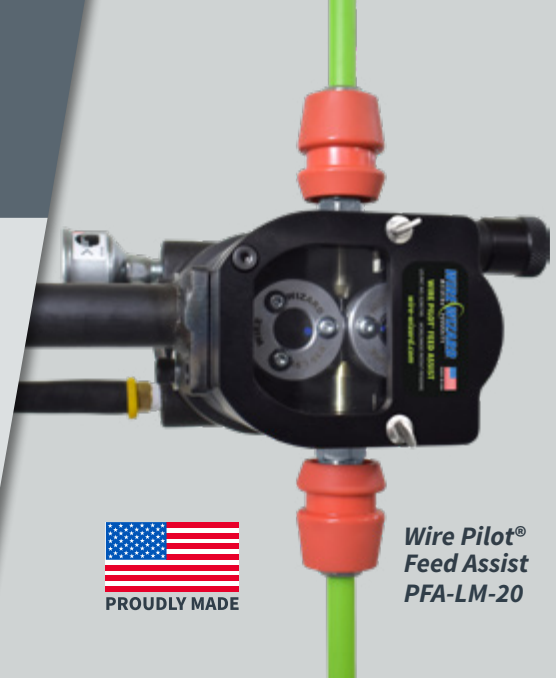

Wire Pilot®  
Feed Assist  
PFA-LM-20



**Spool option**  
WGM-PFA-STAND-SPOOL  
For use with WGM-PFA-STAND.



**Extension Arm**  
PFA-WM-EA  
Fits any Feed Assist Model.



**PFA Drive Rolls**  
Various size options  
All PFA drive rolls are **hard chromed and polished** for maximum performance and durability. Sold individually.

## DUAL DRIVE FEED ASSIST PFA-DD

The new Dual Drive Wire Pilot® Feed Assist is designed to handle large wire up to 3/16" (4.8 mm) and extra-long distance applications using standard size MIG wires. This heavy duty model features four drive rolls (sold separately) and additional torque to provide more power to effortlessly deliver wire to the feeder.

- ▶ Ideal solution for submerged arc welding applications using 1/16" (1.6 mm) and larger wire
- ▶ Utilizes same mounting pattern as the PFA-LM-20 Feed Assist and may be mounted to the same adjustable stands and brackets
- ▶ Compatible with standard Wire Feed Assist drive rolls

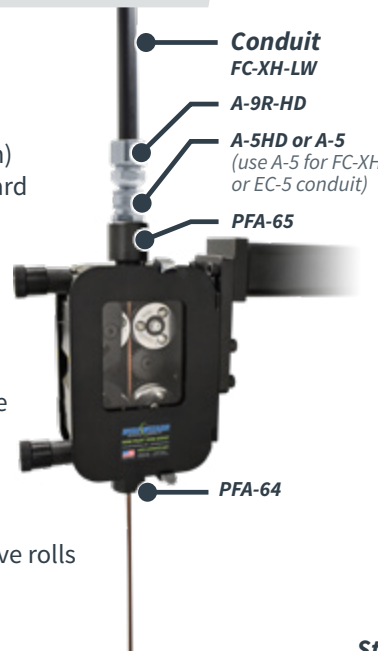

### RECOMMENDED MODELS BY WIRE SIZE & LENGTH OF WIRE DELIVERY RUN

Length	0 - 25 ft	25 - 50 ft	50 - 75 ft	75 ft +
0.030 - 1/16" (0.8 - 1.6 mm) wire	PFA-LM-20	PFA-LM-20	PFA-LM-20	PFA-LM-20 or PFA-DD (with multiple turns for >150 ft)
1/16 - 3/16" (1.6 - 4.8 mm) wire	PFA-DD	PFA-DD	PFA-LM-20 x 2	PFA-LM-20 x 2



**Adjustable Stand for up to 4 Drums, Spools or Wood Reels**  
WGM-PFA-STAND  
Adjusts to 86" (2.2 m); includes 1 arm (additional arms sold separately)

## WIRE PILOT® FEED ASSIST & ACCESSORIES

Part No.	Description
PFA-LM-20	Wire Pilot® Feed Assist with open enclosure, includes PFA-FRL Filter/Regulator/Lubricator
PFA-DD	Wire Pilot® Dual Drive Feed Assist for Large Wires, includes PFA-FRL Filter/Regulator/Lubricator
A-5	Inlet/Outlet Quick Disconnect (insulator U-005 sold separately) for PFA-65
A-1B-C	Inlet Guide with Quick Disconnect for PFA-LM-20
PFA-35-15	Inlet Guide with Ceramic Inlet for PFA-DD or PFA-LM-15 models
PFA-64	Large Wire Inlet Guide with Ceramic Inlet for PFA-DD
PFA-34	Inlet Guide with 3/8"-18 NPS-F threads (connects to A-4HD disconnect) for PFA-LM-20
PFA-35	Inlet Guide with Ceramic Inlet for PFA-LM-20
PFA-65	Inlet/Outlet Guide for PFA-DD, 1/2" NPS-F; two included with each PFA-DD Feed Assist
PFA-DA	Drum Adapter for PFA-LM-20
WGM-PFA-STAND	Adjustable Wire Pilot® Feed Assist Stand for Drums or Spools
WGM-PFA-STAND-ARM	Additional Arm for Wire Pilot® Feed Assist Stand
WGM-PFA-STAND-SPOOL	Wire Spool Holder for Wire Pilot® Feed Assist Stand
WGM-PFA-AK	Wire Pilot® Guide Module® Mounting Adapter (for PFA-LM-20 or older PFA-LM model)
WGM-PFA-AK-15	Wire Pilot® Guide Module® Mounting Adapter (for PFA-LM-15 models only)
WGM-PFA-SW	Wire Pilot® Swivel Kit for Wire Guide Modules (for PFA-LM-20 or older PFA-LM model)
WGM-PFA-SW-15	Wire Pilot® Swivel Kit for Wire Guide Modules (for PFA-LM-15 models only)
PFA-SK	24-volt Pneumatic Solenoid with Cable
PFA-RK	Wire Retract Kit for Reversing Wire Feed (24 V)
PFA-WM-EA	Wire Pilot® Pivoting Extension Arm Bracket (includes wall mount)
PFA-LM-BGA	Replacement Gear Assembly for Bail Side of Feed Assist (for PFA-LM-20 or PFA-LM models)

## WIRE PILOT® FEED ASSIST DRIVE ROLLS

Part No.	Description
PFA-DR-035	Feed Assist Drive Roll for 0.035" (0.9 mm) wire
PFA-DR-045	Feed Assist Drive Roll for 0.045" (1.2 mm) wire
PFA-DR-052	Feed Assist Drive Roll for 0.052" (1.3 mm) wire
PFA-DR-1-16	Feed Assist Drive Roll for 1/16" (1.6 mm) wire
PFA-DR-5-64	Feed Assist Drive Roll for 5/64" (2.0 mm) wire
PFA-DR-3-32	Feed Assist Drive Roll for 3/32" (2.4 mm) wire
PFA-DR-1-8	Feed Assist Drive Roll for 1/8" (3.2 mm) wire
PFA-DR-5-32	Feed Assist Drive Roll for 5/32" (4.0 mm) wire
PFA-DR-3-16	Feed Assist Drive Roll for 3/16" (4.8 mm) wire

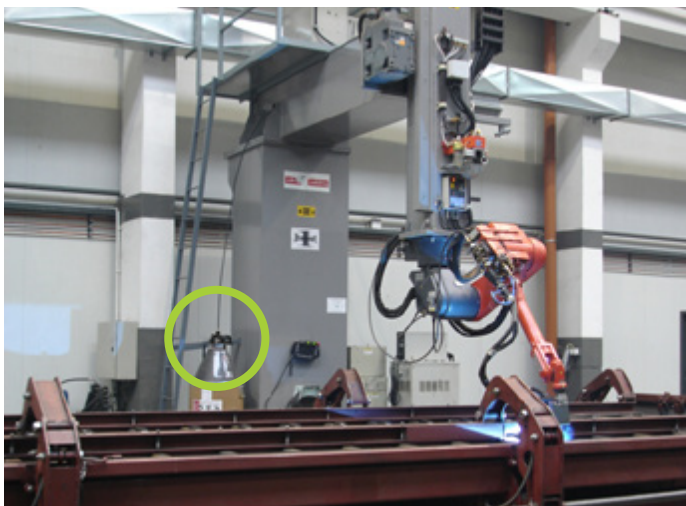

Wire Feed Assist installed in a robotic gantry application.



Tandem Wire Feed Assists Installed on a Mechanical Turn Table.

## WIRE PILOT® FEED ASSIST APPLICATION EXAMPLES

### MOUNTED ON DRUM HOOD

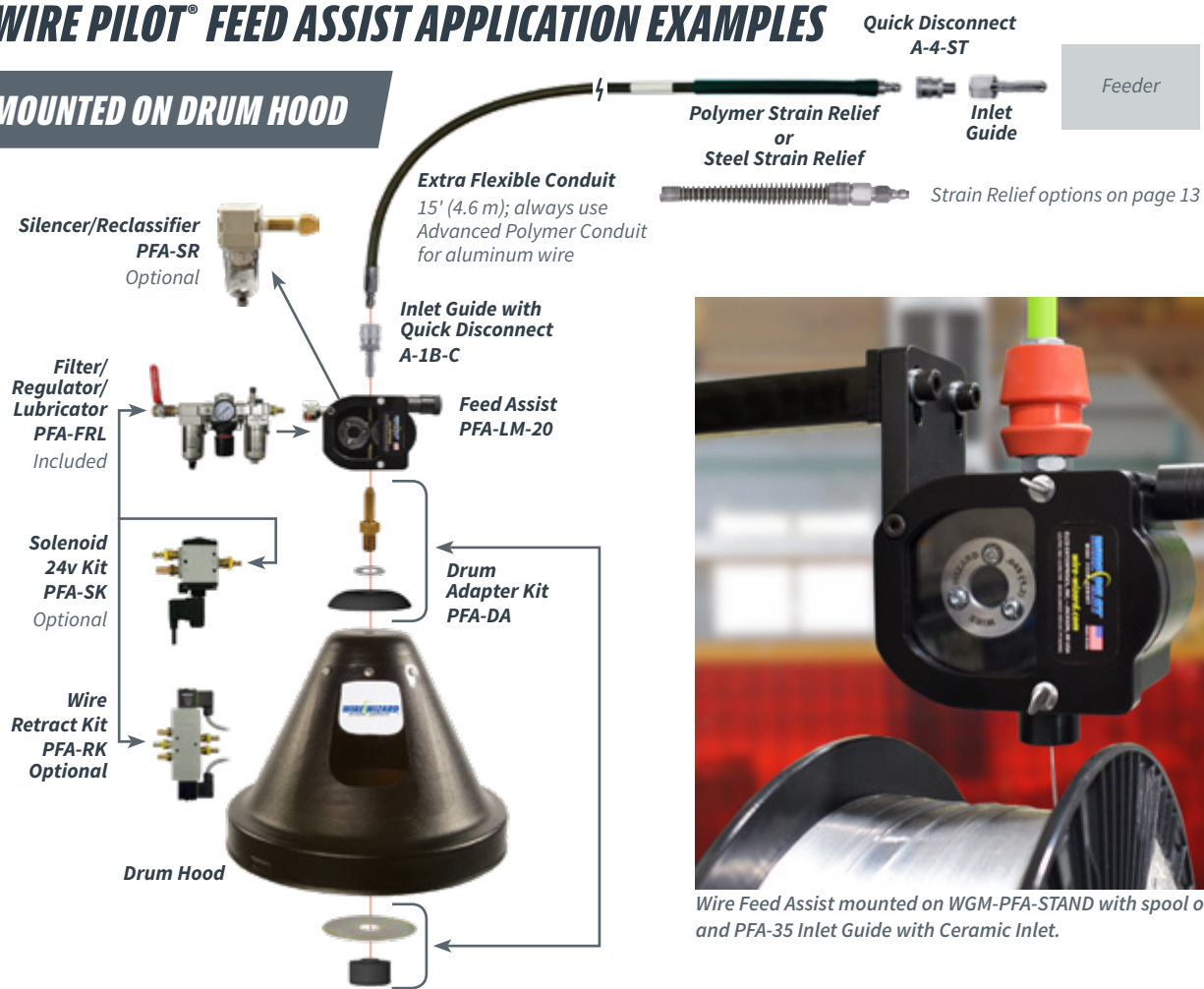

Wire Feed Assist mounted on WGM-PFA-STAND with spool of aluminum wire and PFA-35 Inlet Guide with Ceramic Inlet.

### MOUNTED ON WGM-PFA-STAND Long distance wire feeding application

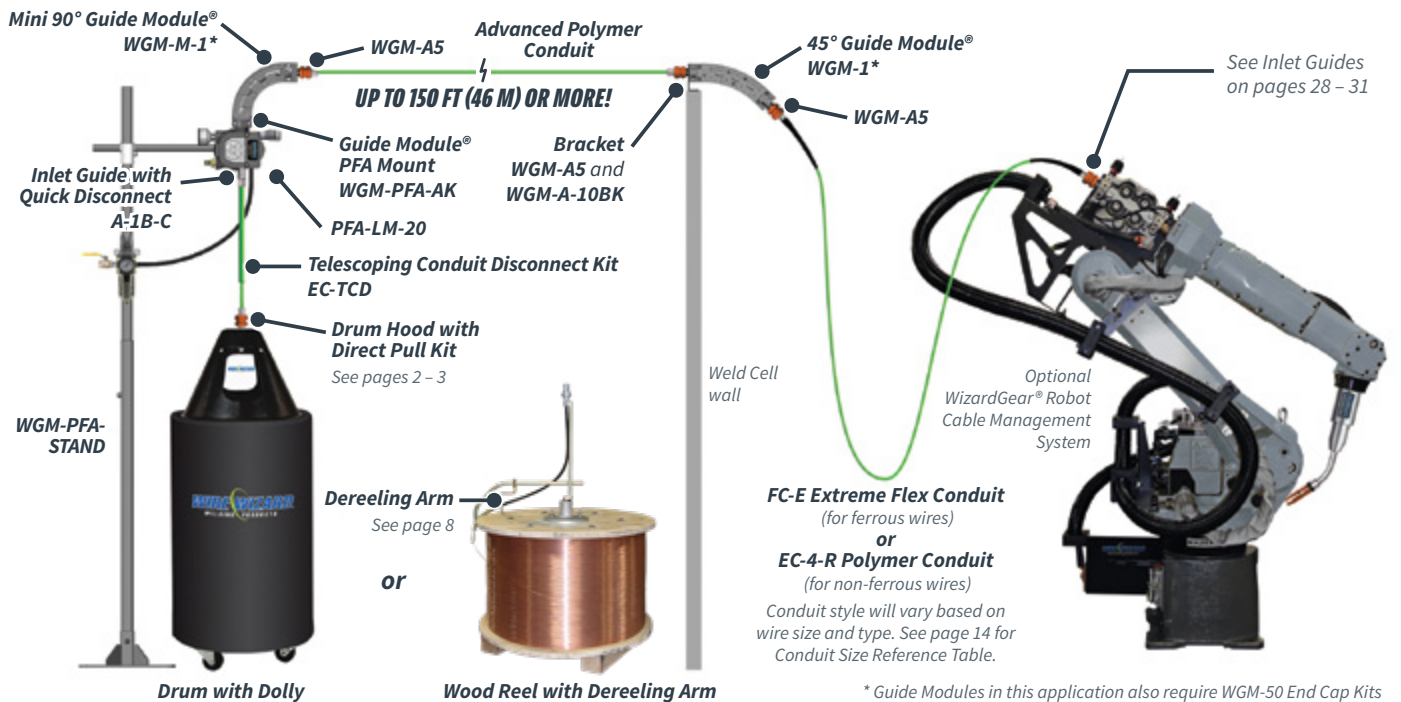

# QUICK DISCONNECTS & INLET GUIDES

## QUICK DISCONNECTS



**A-4-ST or A-4-ST-I** (inc. U-005)  
1/4" NPT-M  
Use with Standard Inlet Guide  
(for brass, request **A-4** or **A-4-I**)



**A-5**  
1/2" NPS-M  
**A-5HD**  
1/2" NPS-M  
(for -LW or -HD connectors)



**A-5FRO**  
Includes M20 threads (for some Fronius® feeders)



Miller® inlet guide

**A-1A-B**  
3/8" clearance for Miller® inlet guides



**A-3**  
1/4" NPT-F\*  
\* See page 31 for thread options



**A-4S**  
1/2" - 20  
(Nut/Washer included)



**A-4HD**  
3/8" NPT-M  
(for -LW or -HD connectors)

### Quick Disconnect Insulator U-005

Fits all disconnects except A-4HD and A-5HD



## STANDARD INLET GUIDES

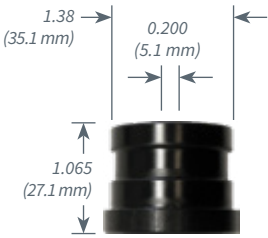

**A-1LN** (Delrin)  
**A-1LN-A** (Aluminum)  
**A-1LN-LW** (Large Wire)  
Lincoln Electric®

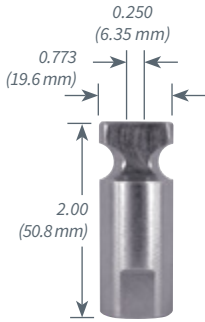

**A-1PA**  
Panasonic®



**A-10TC**  
OTC®/Daihen®

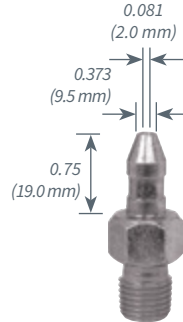

**PAWFS-12**  
Miller® (75)



Use **A-4-ST** (1/4" NPT-M) with fittings above for quick disconnect capability or (brass **A-4** quick disconnect also available)

**A-3**  
1/4" NPT-F

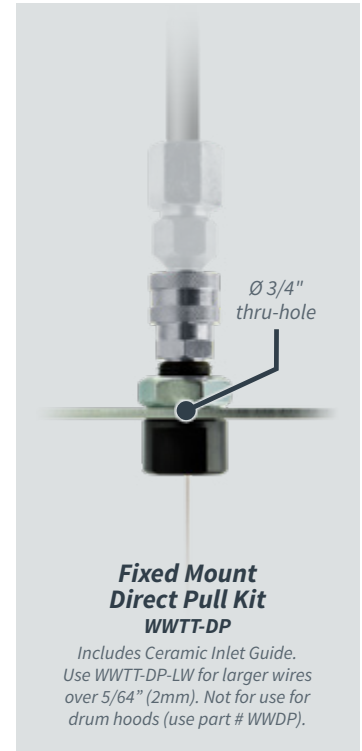

### Fixed Mount Direct Pull Kit WWTT-DP

Includes Ceramic Inlet Guide. Use WWTT-DP-LW for larger wires over 5/64" (2mm). Not for use for drum hoods (use part # WWDP).

## INLET GUIDES WITH QUICK DISCONNECTS

- ▶ For wire feeder and straightener applications
- ▶ Provides trouble-free interface of connections
- ▶ Quick disconnects feature eight retainer bearings

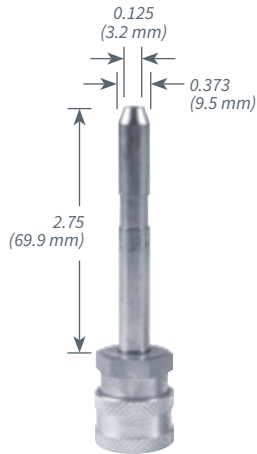
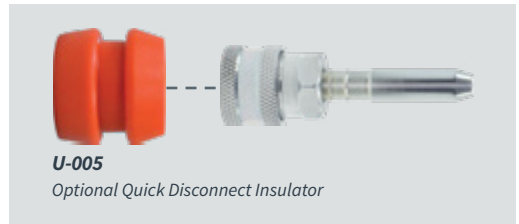

**A-1A**  
0.373 (9.5 mm) Probe

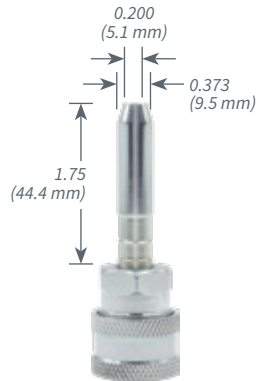

**A-1A-C**  
0.373 (9.5 mm) Probe  
Miller Wire Feeder

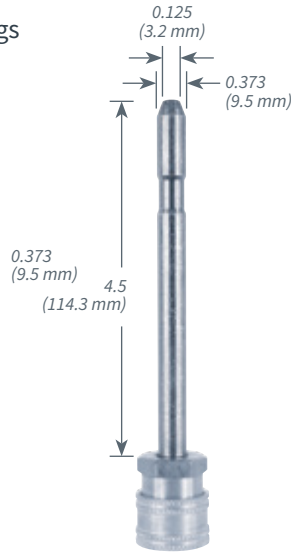

**A-1A-4.5**  
0.373 (9.5 mm) Probe  
Miller Series 74  
Wire Feeder



**A-1LN-23A**  
Lincoln Wire  
Feeder

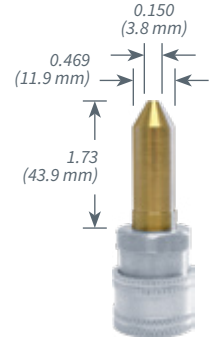

**A-1LN-23B**  
Lincoln Wire  
Feeder

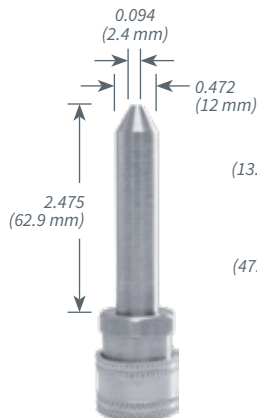

**A-2SKS**  
SKS

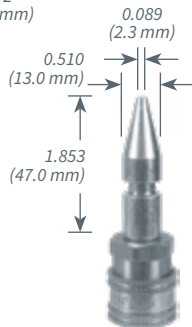

**A-1FRO**  
Fronius Feeder

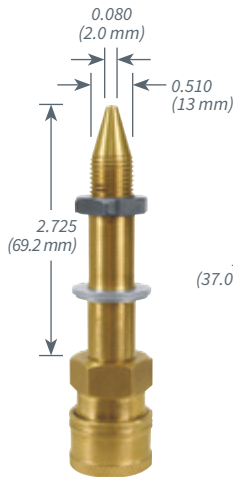

**A-2FRO**  
Fronius Feeder

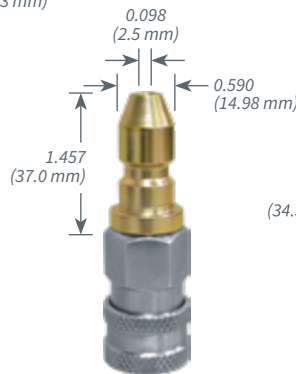

**A-2PA-QD**  
Panasonic  
Wire Feeder

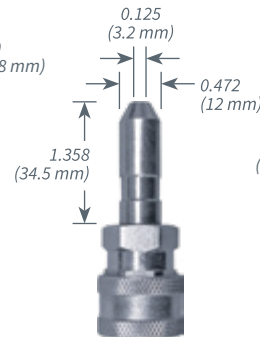

**A-1CL**  
Cloos

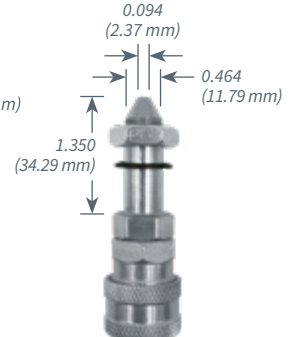

**A-1YAS**  
Yaskawa  
WFE-WFR42DX2

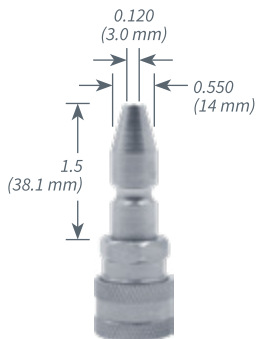

**A-10TC-FX**  
OTC

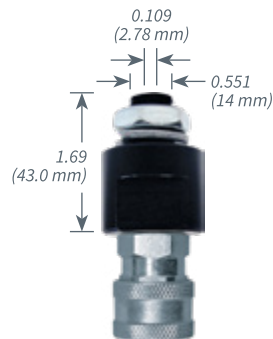

**A-1E-A**  
ESAB RoboFeed  
3004 Series

## CONNECTOR LINERS

- ▶ Designed to line steel connectors when using aluminum and other non-ferrous metal wires
- ▶ Non-metallic to prevent abrasion and contamination



## ADAPTERS FOR FEEDER INLET GUIDES

Configurations shown are just for demonstration purposes only. Please refer to the **Cross-Reference Chart** on page 31 for a complete parts listing for your particular wire feeder.

### UNIVERSAL INLET KIT A-1AK

- ▶ Five piece kit includes A-1A probe and four A-7 phenolic adapter bushings for stable and durable performance
- ▶ Will support the use of a variety of wire feeders

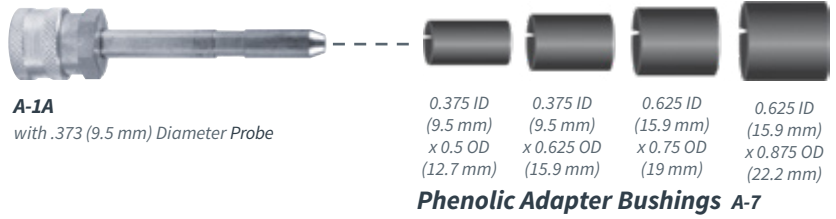

### LINCOLN SERVO INLET GUIDES

- ▶ Designed for use with Lincoln Servo Torch
- ▶ Ideal for all **aluminum and steel** applications
- ▶ Inlet guide connects to **Polymer** or **Extra Flexible** conduit

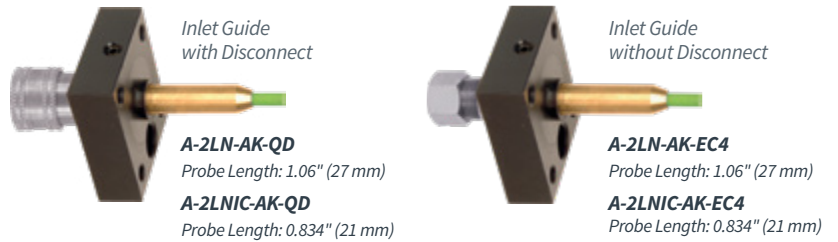

### TWIN-WIRE HYPERFILL® INLET GUIDE FOR LINCOLN ELECTRIC® AUTODRIVE® 4R-220 WIRE FEEDER A-1LN-TW

- ▶ Includes ceramic outlet to eliminate wire friction
- ▶ Compatible with wire sizes up to .052 (1.3mm)
- ▶ Requires the HyperFill® Feeder Kit



### SKS FEEDER ADAPTER A-1SKS

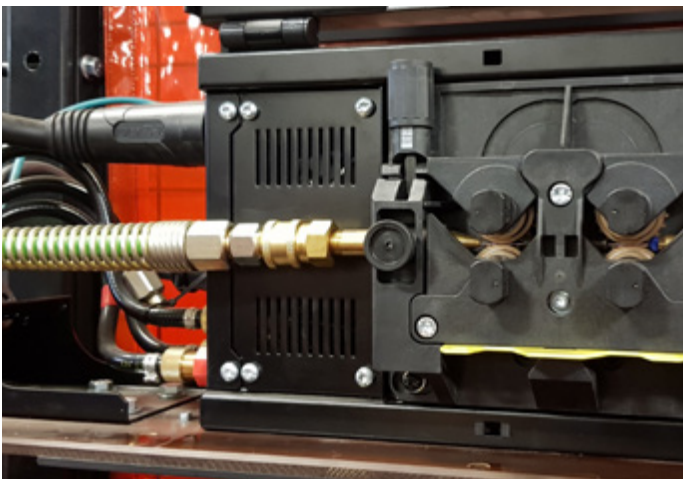

Wire Wizard® inlet guides, conduit and Wire Guide Modules were installed in this optimized wire delivery setup with wire feeders mounted in a fixed position outside the weld cell.

## FEEDER INLET CROSS-REFERENCE CHART

Please verify inlet guide measurements prior to ordering

Feeder Manufacturer	Feeder Type	Wire Wizard® Inlet Guide P/N
CEA S.p.A.	ALL	A-1AK
Cebora S.p.A.	ALL	A-4S
CK Systematics	MP175 and S4165	A-4S
Cloos	Most Models	A-1CL
Cybo Robotics	Most Models	A-4S
ESAB	ALL (except 4-48)	A-1AK
	4-48	A-2E and A-4-ST
	Aristo 30 Series	A-4S
	RoboFeed 3004 Series	A-1E-A
Fronius	Feeder with Set Screw	A-1FRO
	Feeder with Stripped Set Screw	A-2FRO
	SB 500i	A-5FRO
	VR1550	A-1FRO-VR
	WF-25; Reel 4R	A-5FRO
Hobart	Models with 3/4"-16 Thread	A-1A and A-22
	Series 27	A-4-ST
		A-1A, A-1A-4.5
Kobelco	Male Threaded Inlet 1/2"-20	A-3QDF-3
Lincoln Electric	4R100 and 4R220	A-1LN and A-4-ST
	74 HT Flex Feed	A-1LN and A-4-ST
	84M	A-1LN and A-4-ST
	DLF-82	A-1LN and A-4-ST
	LN-7, LN-9, and LN-25	A-1A
	LN-8	A-4-ST
	LF-72	A-1LN and A-4-ST
	LF-74	A-1LN-EK
	MAXsa 29	A-1LN-LW and A-4HD (for large wire) or A-1LN and A-4-ST
	PF Series, inc. PowerFeed® 84	A-1LN and A-4-ST
	Power MIG / Power Wave	A-1LN and A-4-ST
	Series 10 (10M, DH-10, LN-10)	A-1LN and A-4-ST
	Servo Torch	A-2LN-AK

Feeder Manufacturer	Feeder Type	Wire Wizard® Inlet Guide P/N
Miller	22A and 24A	A-1AK
	Auto Access / 50, 60, 70 Series	A-1A-C
	Continuum	A-1A-C
	Intellx®	A-1A-C
	RAD 400	A-1LN-S-12
	Series 74 and R115*	A-1A-4.5 or A-1A-C <i>*Measure required probe length prior to ordering</i>
	Series 75	PAWFS-12 and A-3
MK Products	Cobramatic	A-1AK
Motoman	Female Inlets	A-1A or A-1A-C
	Male Threaded Inlets	A-3QDF-3
OTC/Daihen	AF-4001	A-3QDF-2
	AF-4012	A-10TC-FX
	CM-743U	A-10TC-FX
	CM-741U	A-10TC-FX
	D Series	A-3QDF-4
	FX Style	A-10TC-FX
	Male Threaded Inlet 7/16"-20	A-3QDF-2
	Male Threaded Inlet 9/16"-18	A-3QDF-4
	OTC	A-10TC and A-4-ST
	OTC CM743U	A-10TC-FX
Panasonic	WF-2S Dual Feed	A-10TC-FX
	Female Inlet: .77 OD (19.6 mm)	A-1PA and A-4-ST
	Female Inlet: .57 OD (14.5 mm)	A-2PA-QD
	Male Threaded Inlet	A-3QDF-4
Pow Con	Most Models	A-1AK
SKS	Most Models	A-2SKS
	Older Models	A-1SKS and A-1A-4.5
Yaskawa	YWFR-42-DX2	A-1YAS

This table is intended for the use of Wire Wizard® customers and is provided from relevant information supplied by feeder manufacturers or their distributors who, at their discretion, reserve the right to alter product specifications or features without notice. Every effort has been made to ensure the information presented is accurate and current. If you should require further assistance please contact ELCo Enterprises, Inc.

## LINCOLN ELECTRIC® LF-74 FEEDER INLET GUIDE EXTENSION KIT

### A-1LN-EK

- ▶ Extends connection to the disconnect at the feeder
- ▶ Kit includes A-1LN inlet guide, extension adapter and quick disconnect with insulator

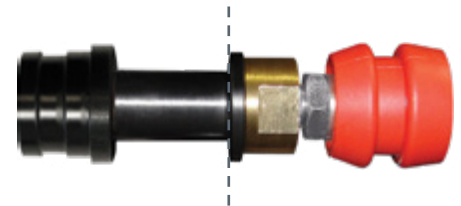

## FEMALE THREADED QUICK DISCONNECT REFERENCE FOR INLET GUIDES

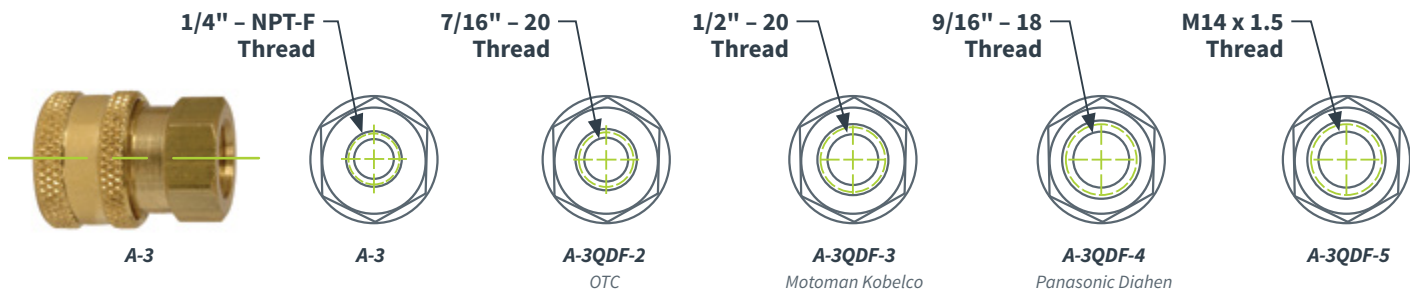



## ROBOT CABLE MANAGEMENT KITS

The **WizardGear®** line of robot cable management kits provide organization, support and protection for all lines and cables attached to robots. Protect cables from damage that can cause unnecessary downtime and costly repairs. Using zip ties or other poor methods of attachment can even void the warranty on your control cables. **Kits with welding cable feature PowerBall® energy efficient cable and consolidated copper lugs.** Kits currently available for Fanuc® robots; additional models coming soon.

- ▶ **Provides organization, support and protection** for all lines and cables attached to robots
- ▶ Protects cables from damage that can cause unnecessary downtime and costly repairs
- ▶ **Approved by Fanuc®** for securing and protecting control cables — other attachment methods may void cable warranty
- ▶ **New models available for latest generation of Fanuc® 100iD and 120iD Robots**
- ▶ Custom cable management systems can be developed for other robot models, contact Customer Support for details



**Deluxe Cable Management Kit for Fanuc® 120iD Robots**  
CM-F-2-ID

Includes protective tubing system and 3/0 welding cable, compatible with most wire feeders.



**Deluxe Cable Management Kit for Fanuc® iC Robots with Part Grippers**  
CM-F-3-MH

Includes CM-F-3 kit components with an additional hose assembly for gripper control cables.



Base Bracket with Insulated Power Lug Connection

**Deluxe Cable Management Kit for Fanuc® 100iD Robots**  
CM-F-1-ID

Part No.	Description
CM-F-1-ID	Deluxe Fanuc® 100iD Robot Cable Management Kit; includes protective tubing system and 3/0 welding cable, compatible w/ most wire feeders
CM-F-1-ID-MC	CM-F-1-ID kit without power cable
CM-F-2-ID	Deluxe Fanuc® 120iD Robot Cable Management Kit; includes protective tubing system and 3/0 welding cable, compatible w/ most wire feeders
CM-F-2-ID-MC	CM-F-2-ID kit without power cable
CM-F-3	Deluxe Fanuc® iC Robot Cable Management Kit; includes protective tubing system, 3/0 welding cable; compatible with Lincoln Electric® wire feeders
CM-F-3-MC	CM-F-3 kit without power cable
CM-F-3-F	Deluxe Fanuc® iC Robot Cable Management Kit; compatible with Fronius® wire feeders (3/0 welding cable)
CM-F-3-F-MC	CM-F-3-F kit without power cable
CM-F-3-MH	Fanuc® iC Robot Cable Management Kit for Robots with Torch/Part Gripper Combination; includes 2 protective tubing systems and 3/0 welding cable, compatible with Lincoln Electric® wire feeders
CM-F-1	Basic Cable Management Kit for 100iC and 120iC; includes base adapter and 3 cable clamp assemblies
CM-F-2	Optional Bracket for Robot Peripheral Cables

\*Add -4/0 suffix to the part number for 4/0 welding cable option

## POWER UP WITH THE POWERBALL® POWER CABLE!

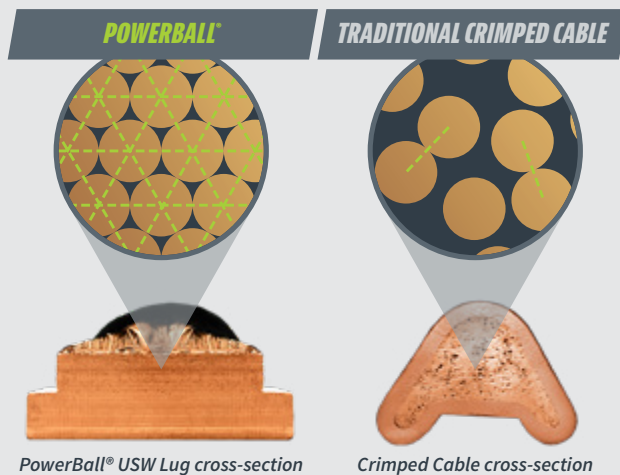

WizardGear® kits feature patented PowerBall® cables with ultrasonically welded lugs for maximum energy efficiency and durability.

## RETRACTABLE CONDUIT/ CABLE BALANCERS & HANGERS

- ▶ Balancer provides easy method of hanging conduit and cables
- ▶ Conduit Hanger prevents excess droopage
- ▶ Prevents cables from hanging in areas prone to damage
- ▶ Hangers feature velcro straps to secure cables and conduit

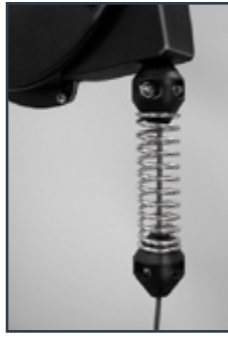

### Heavy Duty Balancers with Shock Stop -SH

Prevents cable damage often caused by over-tensioning

#### Balancers

Several models available, light duty (left) and heavy duty (right)



#### Conduit Hanger

Two sizes available



Part No.	Description
RCH-H	Conduit Balancer — Load: 2 – 4½ lbs (1 – 2 kg)
RCH-5-13	Conduit Balancer — Load: 5 – 13 lbs (2.3 – 6 kg)
RCH-11-19	Conduit Balancer — Load: 11 – 19 lbs (5 – 8.6 kg)
RCH-22-27	Conduit Balancer — Load: 22 – 27 lbs (10 – 12.2 kg)
RCH-22-27-SH	Conduit Balancer with Shock Stop — Load: 22 – 27 lbs (10 – 12.2 kg)
RCH-SH	Shock Stop Kit (only compatible with -SH models)
CHH-10	10" (254 mm) Conduit Hanger with two Retaining Straps
CHH-22	22" (559 mm) Conduit Hanger with four Retaining Straps

## CONDUIT & CABLE SLEEVES

Constructed from Kevlar® with a spatter-resistant silicon coating, Wire Wizard® conduit and cable sleeves provide the maximum degree of protection inside the weld cell.

- ▶ Protects and secures conduit, control cables, cooling lines, gas lines, hydraulic hoses and other lines connected to robots
- ▶ Two I.D. sizes available — 2" (51 mm) and 4" (102 mm) in 1, 2, 3 and 4 ft (305, 610, 914 and 1219 mm) lengths
- ▶ Velcro ends can be chain linked together
- ▶ Sleeve ends accept nylon tie straps
- ▶ Zipper + Velcro enclosure

Part No.	Description	Length
KCS-2-12-S	2" Sleeve (51 mm) I.D.	1 ft (305 mm)
KCS-2-24-S	2" Sleeve (51 mm) I.D.	2 ft (610 mm)
KCS-2-36-S	2" Sleeve (51 mm) I.D.	3 ft (914 mm)
KCS-2-48-S	2" Sleeve (51 mm) I.D.	4 ft (1.2 m)
KCS-4-12-S	4" Sleeve (102 mm) I.D.	1 ft (305 mm)
KCS-4-24-S	4" Sleeve (102 mm) I.D.	2 ft (610 mm)
KCS-4-36-S	4" Sleeve (102 mm) I.D.	3 ft (914 mm)
KCS-4-48-S	4" Sleeve (102 mm) I.D.	4 ft (1.2 m)



Silicon Coated Sleeve



Open sleeve showing velcro and zipper enclosure

# TORCH WIZARD® NOZZLE CLEANING STATIONS

## ROBOTIC NOZZLE CLEANING STATIONS

Torch Wizard® Automatic Robotic Nozzle Cleaning Stations assist in maintaining quality and productivity in MIG welding cells by quickly and efficiently removing spatter build-up in the gas nozzle. The SC models feature a **self-cleaning air blast to clean spatter and other debris** from the blade and air motor. Anti-spatter is applied evenly to the nozzle and tip through an isolated compartment, eliminating wet debris build-up on the reamer blade and motor. **Two year warranty with exclusive use of Blue Magic®/Blue Chill® anti-spatter.**

- ▶ **Extends torch consumable life by removing spatter build-up**
- ▶ **IO-Link or Ethernet option** for connectivity in modern robotic weld cells
- ▶ **Integrated air blast for automated cleaning of spatter and debris** from the reamer motor, reducing downtime for maintenance (on SC models)
- ▶ **Multi-station bulk anti-spatter dispensing** ability standard on all models
- ▶ No circuit boards and fewer moving parts means **more reliable operation and lower maintenance costs**
- ▶ **High torque motor** prevents stalls, reducing downtime
- ▶ Adjustable v-block with four points of contact on the nozzle
- ▶ **Enclosed operating environment** keeps weld cell clean
- ▶ Easy-open covers provide quick access to internal components
- ▶ **TiN coated reamer blades** offer efficiency and longevity
- ▶ **Automated self-diagnostics and maintenance mode**
- ▶ Pneumatic Wire Cutters and Tool Center Point Adapters available

**Note:** Each base unit requires a reamer blade (based on I.D. of gas nozzle being used) and power/control cable. Required FRL is available for purchase.



**Torch Wizard®  
Robotic Nozzle  
Cleaning Station**  
EL-NCS-AC-24-SC  
With optional  
TCP mount

See page 37 for full parts list

NOW WITH  
 **IO-Link**  
CAPABILITY

Anti-Spatter

Air Blast

**Integrated air  
blast for automated  
cleaning of spatter  
and debris!**

Interior View

### TOP VIEW

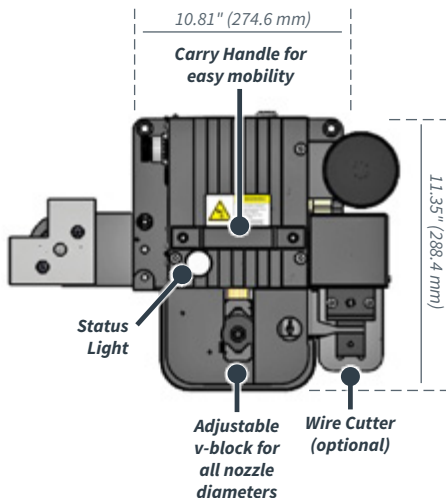

### SIDE VIEW

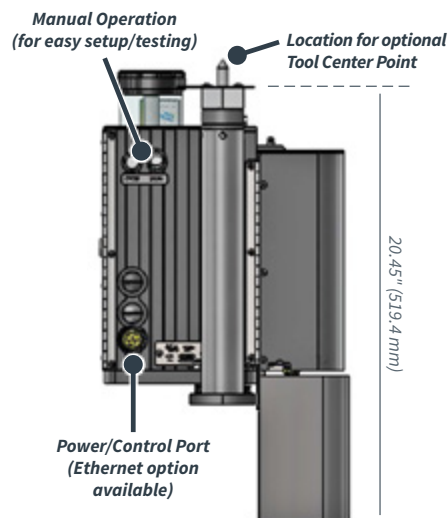

### FRONT VIEW without cover

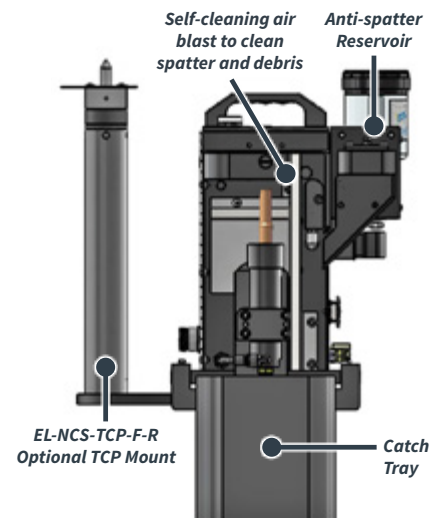

## RELIABLE PERFORMANCE FOR MAXIMUM WELDING PRODUCTIVITY

Manufacturers around the globe trust **Torch Wizard® Nozzle Cleaning Stations** to maximize consumable life and weld cell uptime. Built tough for reliable performance in high volume production applications, they feature no belts that wear out and no complex circuit boards that burn out in industrial environments. Durable titanium nitride coated reamer blades provide extended blade life, reducing maintenance time to replace worn or broken blades. It's the Cleaning Station you need when you want to get the job done, no matter how heavy the workload!



### AUTOMATED SELF-CLEANING FOR EASY MAINTENANCE

Integrated air blast for automated cleaning of spatter and debris

### OPTIONAL WIRE CUTTER

Available wire cutter cleanly cuts wire, removing weld bead for smoother arc starts.

### TITANIUM NITRIDE COATED BLADES

Strong alloy tool steel blades are TiN coated to maintain sharpness and resist breakage.

### BLUE MAGIC® ANTI-SPATTER

Extended two-year warranty with exclusive use of Blue Magic® or Blue Chill® Anti-spatter.



### TOOL CENTER POINT (TCP) MOUNT

Optional TCP mounts available for Fanuc® tool center points.

### BUILT FOR RELIABILITY

No complex circuit boards or belts for reliable, low maintenance operation.

### HIGH TORQUE MOTOR

High torque pneumatic motor prevents stalls and cleans effortlessly!

### ETHERNET OR IO-LINK OPTION

Ethernet or IO-Link capability available for connectivity in modern weld cells.



# TORCH WIZARD®

NOZZLE CLEANING STATIONS

## TORCH WIZARD® TA TANDEM ARC NOZZLE CLEANING STATION

The Torch Wizard® TA Tandem Arc Nozzle Cleaning Station is specially designed for removing spatter build-up in tandem arc torches. Models are available for cleaning Cloos®, Fronius® and Tregaskiss® tandem arc torches. Two year warranty with use of Blue Magic® or Blue Chill® anti-spatter.

- ▶ Quickly and effectively cleans tandem arc torch nozzles, requiring only a simple movement of the torch to ream each side
- ▶ Nozzle clamp (based on torch model) designed specifically for securing tandem arc torches
- ▶ Includes all the same features and uses the same reamer blades as the other Torch Wizard® Nozzle Cleaning Stations
- ▶ Compatible with Fronius®, Tregaskiss® or Cloos® Tandem Arc Systems

Torch Wizard®  
Tandem Arc Nozzle  
Cleaning Station



Innovative design  
cleans tandem  
arc torches  
with ease!

## TORCH WIZARD® REAMER BLADES

Made from alloy tool steel and coated with titanium nitride (TiN) for enhanced durability, our reamer blades maintain their sharp cutting edge and resist breakage. Blades are universal and can also be adapted to other major reaming station manufacturers. Sizes for all nozzle IDs and lengths available (see table on page 37).

- ▶ **TiN coating increases blade life**
- ▶ Single and double flute blades available in a variety of sizes for compatibility with all torch nozzle styles
- ▶ Cost effective replacement blades available for other reaming station manufacturers

**TITANIUM NITRIDE**

TiN Coated for Maximum Durability

Single Flute  
Reamer Blades



Double Flute  
Reamer Blades

Male Threaded Reamer Blades

## INTEGRATED WIRE CUTTER EL-NCS-WCS-12

Included on AC and ACE models

- ▶ Provides simple, automated way to cut wire sizes from 0.035 to 0.062
- ▶ Consistent wire stick-out provides accurate wire location
- ▶ Robust, hardened steel blade offers maximum wear resistance and extended life
- ▶ Fully integrated with the AC and ACE model reaming stations, no additional air or power cables required



## TESTING & DIAGNOSTIC BOX

Includes 110 VAC unit and cable. Available for all cleaning station models.

The Torch Wizard® Reaming Station Test Box is a recommended maintenance peripheral for periodically testing and fine tuning your reaming station.

### Functions include:

- ▶ Sink/Source
- ▶ Motor Slide Up/Down
- ▶ Nozzle Clamp
- ▶ Anti-Spatter Spray
- ▶ Wire Cutter (if applicable)

Cleaning Station Testing  
& Diagnostic Box  
EL-NCS-TB-20



## TORCH WIZARD® ACCESSORIES

### Tool Center Point Adapter Mount EL-NCS-TCP-F-R

Excludes touch plate and point



### 29.5" (749 mm) Stand for Torch Wizard® EL-NCS-STAND

Order **EL-NCS-*STAND*** for AP Model unit and wire cutter

Additional heights available: 12", 20", 36", 48" and 60"



**Cobot Guarding Kit for Reamer & Wire Cutter**  
EL-NCS-CGK-C-24

## TORCH WIZARD® ROBOTIC NOZZLE CLEANING STATIONS STANDARD MODELS

Part No.	Description
EL-NCS-A-24	9-Pin Cleaning Station with Integrated Anti Spatter Spray
EL-NCS-A-24-SC	9-Pin Cleaning Station with Integrated Anti Spatter Spray and Self Cleaning
EL-NCS-AC-24	9-Pin Cleaning Station with Integrated Anti Spatter Spray and a Wire Cutter
EL-NCS-AC-24-SC	9-Pin Cleaning Station with Integrated Anti Spatter Spray, Self Cleaning, and a Wire Cutter
EL-NCS-24	9-Pin Cleaning Station for aluminum
EL-NCS-A-TA-24-CL	Cleaning Station with Integrated Anti-Spatter Spray for Tandem Arc Torches with Cloos® Nozzles
EL-NCS-A-TA-24-FR	Cleaning Station with Integrated Anti-Spatter Spray for Tandem Arc Torches with Fronius® Nozzles
EL-NCS-A-TA-24-TR	Cleaning Station with Integrated Anti-Spatter Spray for Tandem Arc Torches with Tregaskiss® Nozzles

## MODELS WITH INTEGRATED IO-LINK/ETHERNET

Part No.	Description
EL-NCS-AIO-24	IO-Link Cleaning Station with Integrated Anti Spatter Spray
EL-NCS-AIO-24-SC	IO-Link Cleaning Station with Integrated Anti Spatter Spray and Self Cleaning
EL-NCS-ACIO-24	IO-Link Cleaning Station with Integrated Anti Spatter Spray and a Wire Cutter
EL-NCS-ACIO-24-SC	IO-Link Cleaning Station with Integrated Anti Spatter Spray, Self Cleaning, and a Wire Cutter
EL-NCS-AE-24	Ethernet Cleaning Station with Integrated Anti Spatter Spray
EL-NCS-AE-24-SC	Ethernet Cleaning Station with Integrated Anti Spatter Spray and Self Cleaning
EL-NCS-ACE-24	Ethernet Cleaning Station with Integrated Anti Spatter Spray and a Wire Cutter
EL-NCS-ACE-24-SC	Ethernet Cleaning Station with Integrated Anti Spatter Spray, Self Cleaning, and a Wire Cutter

## TORCH WIZARD® OPTIONAL ACCESSORIES

Part No.	Description
EL-NCS-STAND-12	12" (305 mm) stand for EL-NCS models
EL-NCS-STAND-20	20" (508 mm) stand for EL-NCS models
EL-NCS-STAND	29.5" (749 mm) Stand for EL-NCS
EL-NCS-STAND-36	36" (914 mm) stand for EL-NCS models
EL-NCS-STAND-48	48" (1,219 mm) stand for EL-NCS models
EL-NCS-STAND-60	60" (1,524 mm) stand for EL-NCS models
EL-NCS-FRL-14	Filter/Regulator/Lubricator
EL-NCS-CGK-24	Cobot Guarding Kit for Reamer Only
EL-NCS-CGK-C-24	Cobot Guarding Kit for Reamer and Wire Cutter
EL-NCS-TB-20	Testing and Diagnostic Box for 9-pin models
EL-NCS-TCP-F-R	Tool Center Point Mount (attaches to reaming station stand)
EL-NCS-WCS-12	Integrated Wire Cutter (included on AC models)
EL-NCS-WCS-SA-12	Stand Alone Wire Cutter
EL-NCS-CC9-24-3	9 Pin, 20 ft Power/Control Cable

## TORCH WIZARD® REAMER BLADES

Part No.	Description	Diameter	Flutes	Thread	Height
EL-NCS-13MM	Reamer Blade	13 mm	2	Female	2.558"
EL-NCS-TL-13MMF	Reamer Blade	13 mm	1	Female	2.687"
EL-NCS-15MM	Reamer Blade	15 mm	2	Female	2.558"
EL-NCS-TL-15MMF	Reamer Blade	15 mm	1	Female	2.697"
EL-NCS-17MM-L	Reamer Blade (ID: .402")	17 mm	2	Female	3.564"
EL-NCS-17MM-1-L	Reamer Blade (ID: .329")	17 mm	2	Female	3.564"
EL-NCS-500	Reamer Blade ⚡	1/2"	2	Female	2.558"
EL-NCS-TL-50F	Reamer Blade ⚡	1/2"	1	Female	2.687"
EL-NCS-TS-50F	Reamer Blade ⚡	1/2"	1	Female	2.433"
EL-NCS-625	Reamer Blade ⚡	5/8"	2	Female	2.558"
EL-NCS-TL-62F	Reamer Blade ⚡	5/8"	1	Female	2.687"
EL-NCS-TS-62F	Reamer Blade ⚡	5/8"	1	Female	2.433"
EL-NCS-750	Reamer Blade ⚡	3/4"	2	Female	2.558"

## MALE THREADED REAMER BLADES for other reaming stations

Part No.	Description	Diameter	Flutes	Thread	Height
EL-NCS-TS-13MM	Reamer Blade	13 mm	1	Male (3/8" - 24)	2.433"
EL-NCS-50-M	Reamer Blade	1/2"	2	Male (3/8" - 24)	2.558"
EL-NCS-TL-50	Reamer Blade ⚡	1/2"	1	Male (3/8" - 24)	2.687"
EL-NCS-TS-50	Reamer Blade ⚡	1/2"	1	Male (3/8" - 24)	2.433"
EL-NCS-625-M	Reamer Blade ⚡	5/8"	2	Male (3/8" - 24)	2.558"
EL-NCS-TL-62	Reamer Blade ⚡	5/8"	1	Male (3/8" - 24)	2.687"
EL-NCS-TS-62	Reamer Blade ⚡	5/8"	1	Male (3/8" - 24)	2.433"

⚡ Blades compatible with PowerBall® Torch Consumables

Please call Customer Support for correct retrofit reamers for: ABICOR Binzel®, Intertech®, Tregaskiss® and Nasarc®

# ANTI-SPATTER & ACCESSORIES

## BLUE MAGIC® ANTI-SPATTER & NOZZLE CLEANER

Blue Magic® is a water-based and nontoxic anti-spatter formulated to provide superior performance in demanding industrial applications. The biodegradable formula contains no harmful chemicals and is noncombustible. Contains no oils or silicone, making it safe for parts to go straight from production to paint.

- ▶ **Water-based and non-toxic formula** – contains no methylene chloride or other hazardous chemicals
- ▶ **Industrial strength protection against spatter build-up** – Excels in applications where quality is a must
- ▶ **New! Nonflammable, air-powered can with the same trusted formula** – Utilizing only noncombustible air for a propellant, it features a glove-friendly trigger and 360° spraying ability
- ▶ **Safe for paint** – No oils or silicone that negatively affect paint
- ▶ **Environmentally friendly** – Biodegradable, no carcinogens, recyclable can
- ▶ **Available in concentrated form in 5 gallon buckets or 1 liter bottles**
  - ▶ One 5 gallon bucket makes 55 gallons of anti-spatter, ideal for overseas shipping



Drum Pump for 55 gallon drums

Anti-spatter samples available upon request

## BLUE MAGIC® HD HIGH DUTY CYCLE ANTI-SPATTER



Introducing our toughest anti-spatter yet! Blue Magic® HD anti-spatter is specially formulated for extremely high temperature, long duty cycle applications.

- ▶ Special formula provides maximum protection
- ▶ Will not evaporate, even under extreme heat
- ▶ Reduces downtime for clean-ups in long duty cycles that generate extreme heat and excessive spatter

Part No.	Description
EAS1000-HDC32	32 oz Spray Bottle
EAS1000-HDC1	1 gal Bottle
EAS1000-HDC5	5 gal Container
EAS1000-HDC	55 gal Drum

VISIT [WIRE-WIZARD.COM](http://WIRE-WIZARD.COM) FOR SDS SHEETS

# BLUE MAGIC® ANTI-SPATTER



SCAN HERE FOR BROCHURE



## NEW! NONFLAMMABLE AIR-POWERED CAN!

### BLUE MAGIC® ANTI-SPATTER

Part No.	Description
EAS1000-CTC	1.7 oz Trial Spray Can
EAS1000-CSC	14 oz Air-powered Spray Can
EAS1000-C32	32 oz Spray Bottle
EAS1000-C1	1 gal Bottle
EAS1000-C5	5 gal Container
EAS1000-C	55 gal Drum
EAS1000-CT	275 gal Bulk Tote
EAS1000-C-CON-1L	1 l (33 oz) Concentrate
EAS1000-C-CON-5	5 gal Concentrate
EAS1000-DP	Manual Drum Pump (55 gal)

## BLUE CHILL® ANTI-SPATTER & NOZZLE COOLANT

Increase weld productivity with this specially blended formula that not only protects surfaces from spatter, slag, and scale but also **quickly cools down hot nozzles!**



- ▶ Extends nozzle and contact tip life
- ▶ Will not evaporate
- ▶ Environmentally safe, non-toxic, biodegradable



Part No.	Description
EAS1000-BC32	32 oz Spray Bottle
EAS1000-BC1	1 gal Bottle
EAS1000-BC5	5 gal Container
EAS1000-BC	55 gal Drum
EAS1000-BCT	275 gal Bulk Tote

## 5-GALLON MANIFOLD KIT 5GMK

This popular industrial size dispenses **Blue Magic®** or **Blue Chill®** anti-spatter to **Torch Wizard®** pneumatic reamers and nozzle mist applicators. Easily integrated into any weld cell stations.

- ▶ Smaller footprint is ideal where space is an issue
- ▶ Pneumatic pump supplies 1.92 gallons per minute at 75 psi
- ▶ Bulk dispensing system easily supplies up to 15 work stations (depending on distance)

### SPECIFICATIONS

- ▶ Height: 27" (685.8 mm)
- ▶ Width: 11.25" (285.7 mm)
- ▶ Depth: 14" (355.6 mm)
- ▶ Weight: 8 lbs (3.6 kg)



## DRUM MANIFOLD KIT DMK

Designed to deliver bulk **Blue Magic®** or **Blue Chill®** anti-spatter to multiple **Torch Wizard®** nozzle cleaning and/or spraying stations, eliminating the need to refill small, gravity fed containers on a frequent basis. **Optional gauge** monitors fluid level for easier maintenance. Easy to install.

- ▶ Lowers operating costs by allowing the use of bulk anti-spatter, reduces downtime for refilling
- ▶ Supplies anti-spatter to multiple stations with pneumatic pump (pumps up to 1.92 gallons per minute at 75 psi)
- ▶ Less space required due to one feeding source



## ANTI-SPATTER MULTI-STATION DISPENSING SYSTEM SETUP

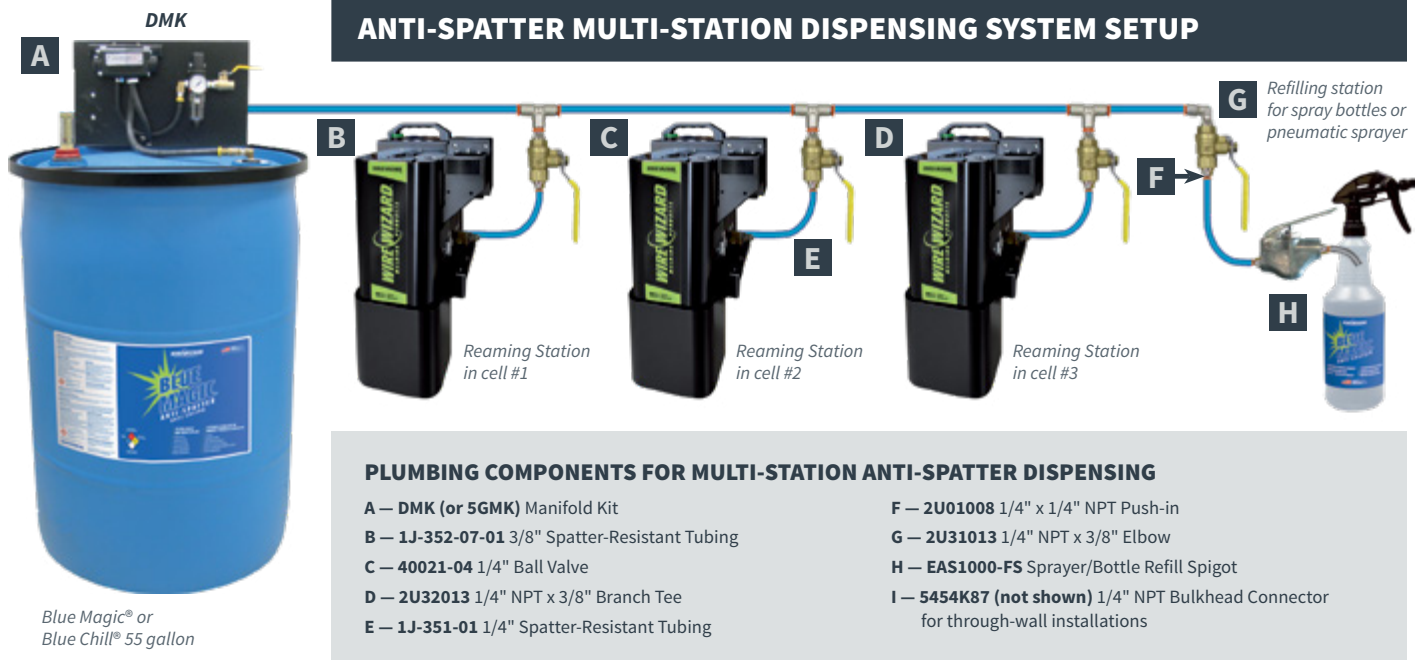

# WIRE TRACKER™ DIGITAL WIRE MONITOR

## ACCURATE WIRE TRACKING & MONITORING IN ONE DEVICE

WC-1-WS-S

The **Wire Tracker™ Digital Wire Monitor** provides an easy way to monitor and track wire in robotic or semi-automatic MIG welding applications. The device may be mounted in-line for 24/7 monitoring or used as a portable unit to check wire usage per weld or wire feed speed. It provides a simple and accurate method for monitoring and totalizing wire consumption, or measurement and verification of wire feed speed.

- ▶ **Tracks and totalizes wire consumption** — an easy way to determine wire usage per weld and amount of time a wire package will last
- ▶ Install in-line for constant monitoring or use as a portable device to check and verify wire feed speed and wire usage (rechargeable li-ion battery included)
- ▶ Includes **Wire Speed Sensor** to monitor wire feed speed (WFS) and wire consumption
- ▶ Optional **Motor Current Sensor** monitors the workload on the wire feeder, which can detect and send alerts on wire feeding issues
- ▶ Monitors wire remaining and **sends alert when wire package is low**
- ▶ Exported data may be used to **track total wire feed time** to help determine welding productivity
- ▶ Documents historical data for each weld, including: Timestamp, Duration (time of active wire feed), Average wire feed speed (WFS), and Wire Consumed. Data is downloadable via USB connection to a PC.
- ▶ PLC connectivity allows automated alert functions



WIRE TRACKER™

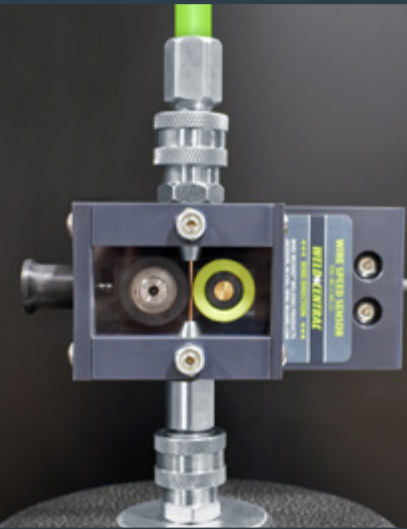

WIRE SPEED SENSOR

### SOFTWARE FEATURES

- ▶ View and export time-stamped wire usage data (per weld), including duration of wire feed, wire feed speed (in IPM or MM/SEC), wire consumed and wire remaining
- ▶ Edit or refill wire
- ▶ Quickly view the wire remaining
- ▶ Options for measurement units in Imperial (US) or Metric
- ▶ Ability to connect to multiple Wire Trackers at once

Chart and Wire Refill screen

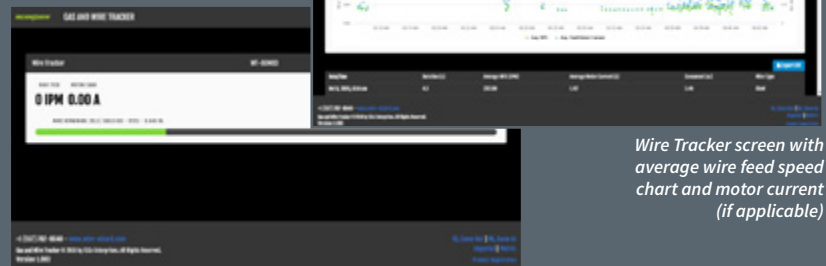

Wire Tracker screen with average wire feed speed chart and motor current (if applicable)

Part No.	Description
WC-1-WS-S	Wire Tracker™ Digital Wire Monitor — Includes Wire Feed Sensor
WC-1-MS	Add-on Feed Motor Current Sensor for monitoring and tracking of wire delivery issues
WC-1-WS-RECAL	Wire Sensor Calibration Service (yearly recalibration recommended)
WC-1-MS-RECAL	Motor Current Sensor Calibration Service (yearly recalibration recommended)

# GAS FLOW MONITORING & OPTIMIZATION

## GAS TRACKER™ GAS FLOW MONITOR

WC-1-GS-S

The **Gas Tracker™ Digital Gas Flow Monitor** provides an easy way to monitor and track shielding gas flow in MIG or TIG welding applications. The Gas Tracker™ is **two monitors in one** — for use as a portable unit or mounted in-line. It provides a simple and accurate method for monitoring and totalizing incoming gas flow, or measurement and verification of gas flow at the nozzle.

- ▶ **Portable Application:** Check and verify gas flow at the nozzle to avoid porosity and other serious weld quality issues. Each monitor includes a hose and filter assembly that fits all standard nozzle sizes, along with a rechargeable li-ion battery that lasts up to 24 hours.
- ▶ **In-line Application:** The monitor can function as a gas totalizer, verify proper gas flow and keep a record of average gas flow per weld (data downloadable via USB connection).
- ▶ Touchscreen interface with digitally displayed flow rate of 0 – 106 SCFH (0 – 50 LPM) with 1 SCFH resolution in Imperial or Metric units.
- ▶ PLC connectivity allows automated alert functions.
- ▶ Pre-calibrated for a variety of gas mixture options, including: Argon/CO2 (90/10, 85/15, 80/20, 98/2 or 75/20), Argon/Helium (75/25), Argon/O2 (97/3), He/Ar/CO2 (90/7.5/2.5) and 100% Argon, CO2, Helium or Nitrogen.
- ▶ NIST traceable calibration certificate included
- ▶ Dimensions: 7" (178 mm) X 5.25" (134 mm) X 3.25" (83 mm)



### INLINE APPLICATION



### PORTABLE APPLICATION

#### SOFTWARE FEATURES

- ▶ View and export time-stamped gas flow data (per weld), including duration of flow, gas flow rate (in CFH or LPM), gas consumed and gas remaining
- ▶ Edit or refill gas (if applicable)
- ▶ Quickly view the gas remaining
- ▶ Ability to connect to multiple Gas Trackers at once

Gas and Wire Tracker screen with gas flow chart



Chart and Gas Refill screen



## MANUAL GAS FLOW GAUGES EL-GFM

Measures the actual flow of shielding gas from the MIG/TIG torch, allowing adjustments to be made at the cylinder gauge if necessary. An economical solution for improving overall welding performance.

- ▶ Features flexible hose for easy operator readings on robotic torches
- ▶ Measures gas flow consumption (CFH or LPM) at nozzle; up to 60 CFH/28 LPM

Part No.	Description
WC-1-GS-S	Gas Tracker™ Digital Gas Flow Monitor — In-line or portable use for checking flow at the nozzle
WC-1-GS-RECAL	Gas Tracker™ Digital Gas Flow Monitor Calibration Service (yearly recalibration recommended)
EL-GFM	Manual Gas Flow Gauge for Robotic Applications

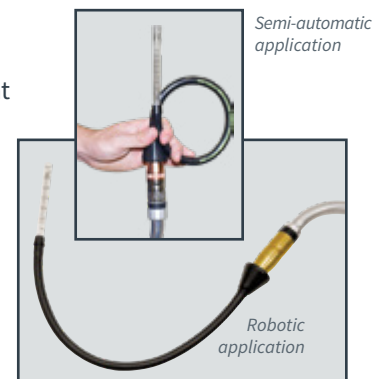



**SAVE 35% OR MORE  
ON INERT GAS**



## ADJUSTABLE GAS SAVERS

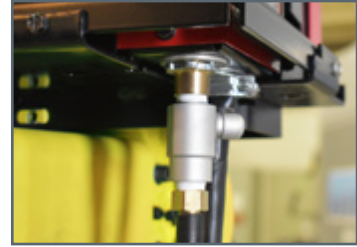

Installation at gas inlet on the wire feeder

**Gas Wizard™ Inert Gas Savers** are designed to reduce gas consumption by restricting the gas surge that occurs at arc initiation. The **Adjustable Gas Saver** is ideal for virtually all welding applications and allows fine tuning of the gas flow, which is an added benefit for facilities utilizing long bulk gas delivery systems with pressure drops.

- ▶ **Reduces gas consumption** in MIG or TIG applications
- ▶ Restricts gas surge upon arc starts, screen prevents blockages
- ▶ Gas savers available for the inlet or outlet side of gas solenoid



**Adjustable Gas Savers**  
*GFJ-ADJ-A, B, C or D*  
Saves gas and allows fine tuning of gas flow



**GFJ-ADJ-A**  
5/8"-18 Male x  
5/8"-18 Female



**GFJ-ADJ-B**  
1/4"-18 Male NPT x  
5/8"-18 Female NPT



**GFJ-ADJ-C**  
1/4"-18 Male NPT x  
1/4"-18 Female NPT



**GFJ-ADJ-D**  
1/4"-19 Male BSPP x  
1/4"-19 Female BSPP

### ADJUSTABLE GAS SAVER OPTIONS

Part No.	Description
GFJ-ADJ-A	5/8"-18 Male x 5/8"-18 Female
GFJ-ADJ-B	1/4"-18 Male NPT x 5/8"-18 Female NPT
GFJ-ADJ-C	1/4"-18 Male NPT x 1/4"-18 Female NPT
GFJ-ADJ-D	1/4"-19 Male BSPP x 1/4"-19 Female BSPP



### GAS SAVINGS AS A RESULT OF ELIMINATING GAS SURGE UPON ARC START

Spikes represent gas surge at arc start **without** gas saver installed

- Flow Meter
- Gas Saver
- Gas Savings

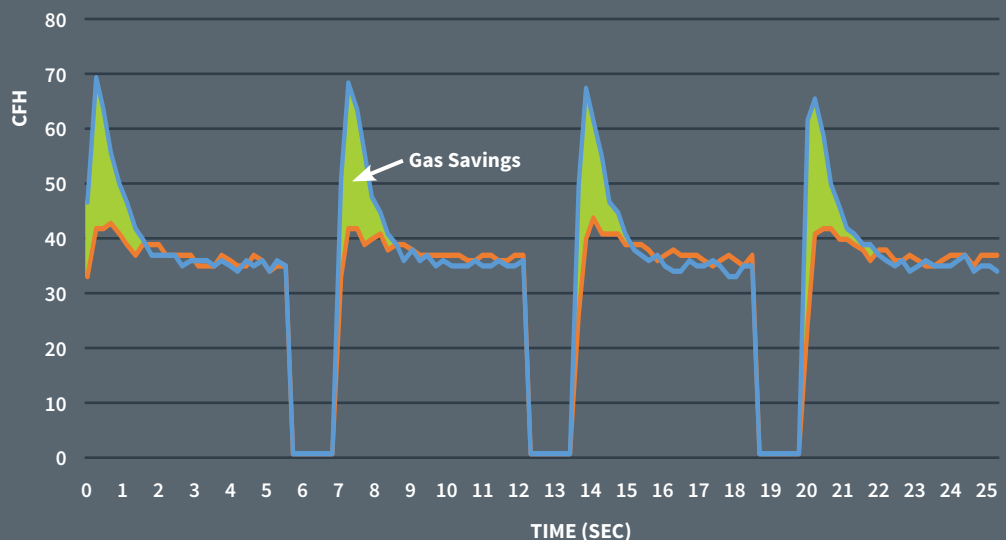

# TOOLS & MAINTENANCE EQUIPMENT

## WIRE FEED SPEED SENSOR *HHSS-12*

This hand-held, battery operated tachometer is capable of measuring and retaining RPH, RPM, FPH, FPM and MPH. Standard accessories include: 3-1/2" (89 mm) extension shaft, one funnel and two cone adapters, master wheel (6" / 152 mm) and carrying case. Designed for accurate wire feed speed measurement at the torch end.

*Manual application only. Does not take continuous readings.*

- ▶ Plugs into existing wire system and conduit
- ▶ Handles wire diameters from 0.030 – 0.125 (0.8 – 3.2 mm)
- ▶ Rugged aluminum construction with Delrin wire guide head
- ▶ Displays wire speed with automatic floating decimal point
- ▶ Large 13 test memory selectable to 5 minutes or more

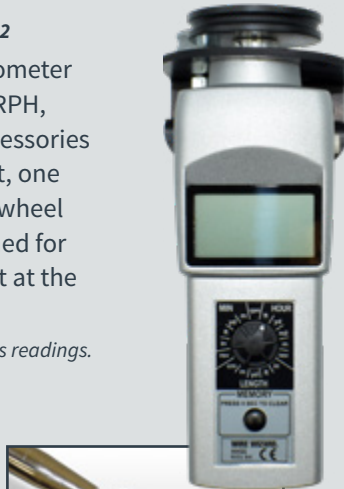

*HHSS-12 obtaining measurement at the torch end*

## WIRE DRAW GAUGE *WWPT*

- ▶ Accurately measures the draw weight of wire pulling through the conduit
- ▶ Helps determine if conduit needs changed by the amount of strain the wire is creating on the feed motor
- ▶ Hand-held, battery powered (9 V).
- ▶ Capable of averaging 10 pulls of wire, storing the largest draw
- ▶ Measures in English or metric
- ▶ Easy to read 5-digit LCD display
- ▶ Ergonomic plastic housing with standard storage case
- ▶ Max pull weight: 12 lb (5.4 kg)

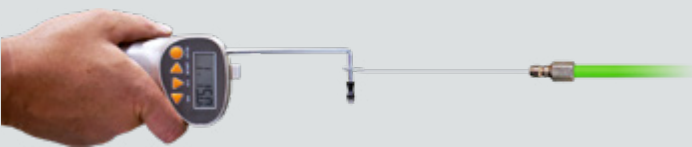

## MULTIFUNCTION WIRE & WELDING PLIERS *EL-WP*

**INCLUDES TOOL BELT POUCH**



- ▶ Rounded tips for sharply bending wire for easy feeding through the wire delivery system
- ▶ Ideal for servicing and maintaining consumables and removing spatter build-up
- ▶ Heavy duty chrome vanadium steel

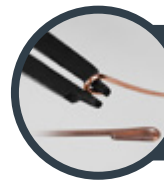

**BENDS WIRE FOR EASY FEEDING THROUGH SYSTEM**

## CONDUIT ASSEMBLY TOOLS



### Conduit Deburring Stone *EC-DS*

*For deburring sharp edges on steel-lined conduit*



### Polymer Conduit Countersink Tool *EC-DB*

*Ratcheting tool for countersinking the ends of polymer conduit (required for proper installation)*

### Polymer Conduit Cutter *EC-CUTTER*

*Trims all sizes of polymer conduit with ease. Heat treated steel cutting blade. 8.5" (216 mm) long.*



## NEW! WIRE DELIVERY INSTALLATION KIT *WW-ATK*

Includes Wire Draw Gauge, Welding Pliers, Conduit Cutter, Deburring Stone and Countersink Tool in a convenient soft storage case



# POWERBALL<sup>®</sup>

## TORCH PRODUCTS

### POWER UP YOUR WELDING PERFORMANCE!

Welders are all too familiar with that "popcorn popping" sound heard when using a welding gun with poor conductivity. PowerBall Handheld and Robotic MIG Torches by Wire Wizard feature an innovative design that maximizes conductivity, optimizing arc stability and eliminating poor arc starts so the start of the weld is just as good as the end. Choose PowerBall technology for quality welds that are **All Butter, No Popcorn!**<sup>™</sup>



### ALL BUTTER, NO POPCORN!<sup>™</sup>



#### MIG WELDING GUNS

300, 400 and 500 A models available



#### REPLACEMENT CONSUMABLES

Available for most torch manufacturers



#### ROBOTIC MIG TORCHES

Compatible with most thru-arm robots

#### GOOD ARC STABILIZATION

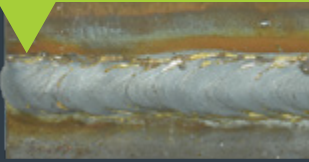

WELD COMPLETED WITH POWERBALL<sup>®</sup> TORCH

#### POOR ARC STABILIZATION



WELD COMPLETED WITH COMPETITOR'S TORCH

Two welds were completed with .045 carbon steel wire, one with a good Arc Stabilization Period (ASP) and one with a poor ASP. The weld completed using the PowerBall<sup>®</sup> MIG Gun had a much faster ASP, with a quality weld bead from start to finish. The weld with a bad ASP had a longer period of current volatility when first establishing the arc, resulting in poor weld quality at the start of the weld. This can result in numerous bad parts and rework, especially with shorter welds.



#### SCAN HERE TO VIEW THE FULL POWERBALL PRODUCT LINE

See the difference PowerBall<sup>®</sup> technology can make at your facility! Visit our website or contact your Wire Wizard Technical Sales Expert to request a PowerBall<sup>®</sup> semi-automatic or robotic MIG gun trial package.



**FAMILY OWNED**  
**AMERICAN MADE**

ELCo Enterprises, Inc. offers UPS shipping from our regional distribution centers, including:

- ▶ Ground (see maps)
- ▶ Next Day Air
- ▶ 2nd Day Air
- ▶ 3 Day Select
- ▶ International Service

VISIT  
**WIRE-WIZARD.COM/DISTRIBUTION**  
FOR A LIST OF OUR  
INTERNATIONAL DISTRIBUTORS



## SHIPPING TRANSIT TIMES FOR UPS GROUND

Orders may be available for pick up from our distribution center locations. Contact Customer Support for details.

1 day 2 days 3 days 4 days 5 days

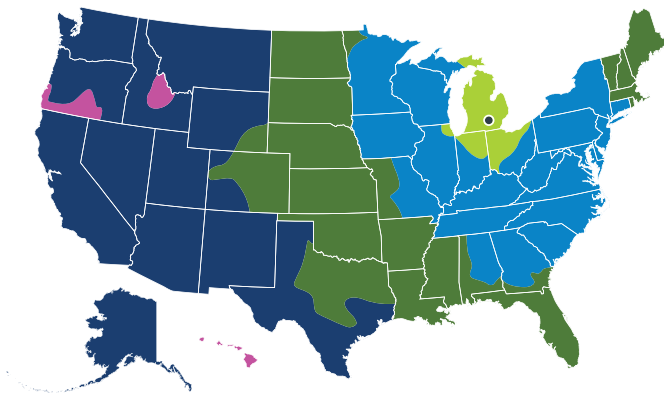

### JACKSON, MI HEADQUARTERS

5750 Marathon Drive  
Jackson, MI 49201

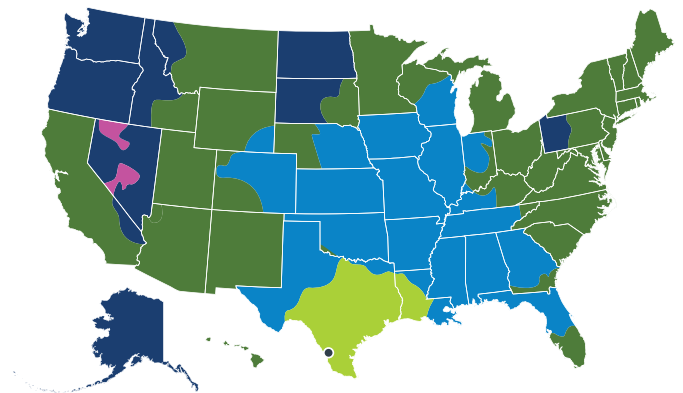

### LAREDO, TX DISTRIBUTION CENTER

Laredo, TX 78040  
Also provides fast shipping to Mexico (transit times will vary)

## TERMS AND CONDITIONS

“We,” “us,” and “our” refer to ELCo Enterprises, Inc.

### ORDERING

Wire Wizard products are available worldwide through our distribution network and are offered by most distributors of welding equipment in North America. Our Customer Support staff is available Monday-Friday, 8:00am-5:00pm (EST) at our main office by calling 517-782-8040. Any orders placed after noon EST for same day shipping will be charged a \$75 expedite fee. When ordering, please state your company’s “bill to” and “ship to” address, purchase order number, part number, quantity, item description, and any special shipping instructions. All purchases will be shipped UPS ground unless otherwise specified. Items too large for UPS, will be shipped by commercial carrier.

**\$75 minimum order.**

### NOTE

Purchases cannot be delivered to post office boxes.

### SPECIAL ORDERS

If a specialized part is required, please consult our Customer Support staff for a quote. There are no returns on special order items.

### TERMS

All orders placed on account are net 30 days. Unpaid balances are subject to a 1% per month late charge. COD orders are accepted if payment is in the form of a company check, certified check, or money order.

### RETURNS

All returns must be in new condition and authorized by ELCo by use of a Returned Merchandise Authorization Number (RMA). Returns are subject to a restocking fee.

### DISCLAIMER

Every effort has been made to avoid any printing errors in this catalog. Consequently, we do not claim responsibility for any application or specification errors. Wire Wizard® products are intended for use with other Wire Wizard® products. Use with any other manufacturer’s products may void the warranty. Any reproduction of artwork, photographs, or any other portion of this catalog without prior written consent of ELCo Enterprises, Inc. is a violation of our copyright. Violators will be prosecuted.

# **SOLVING WELDING CHALLENGES & MANUFACTURING INNOVATIVE WELDING PRODUCTS SINCE 1985**

**Wire Wizard® Welding Products** is recognized as the industry leader in weld wire delivery products, high performance torch products, weld cell support equipment and weld cell optimization. Since we began in 1985, we've prided ourselves on both quality and innovation. Our product lines include Wire Wizard® Wire Delivery Equipment, Blue Magic® Anti-spatter, PowerBall® Torch Products, Torch Wizard® Nozzle Cleaning Stations and WizardGear® Robot Cable Management Systems. Wire Wizard® has solutions for virtually every arc welding application, including robotic, fixed automation, semi-automatic and submerged arc welding.



ELCo Enterprises headquarters in Jackson, Michigan

## **ELCO ENTERPRISES, INC.**

5750 Marathon Drive  
Jackson, Michigan 49201 USA

**Phone** 517.782.8040

**Email** sales@wire-wizard.com



 /WireWizardUS

 @WireWizardUS

 /elco-enterprises-inc

 /WireWizardUS

 @WireWizardUS

**WIRE WIZARD® WIRE DELIVERY EQUIPMENT**  
**POWERBALL® TORCH PRODUCTS**  
**LOW FRICTION CONDUIT & CONNECTORS**  
**WIRE WIZARD® GUIDE MODULE® SYSTEM**  
**WIZARDGEAR® CABLE MANAGEMENT**  
**BLUE MAGIC® & BLUE CHILL® ANTI-SPATTER**  
**TORCH WIZARD® CLEANING STATIONS**  
**DRUM & REEL HANDLING EQUIPMENT**



**ISO 9001:2015  
CERTIFIED**